

# *280 Log Effect Stove*

## *Balanced Flue*

### **Instructions for Use, Installation and Servicing**

**For use in GB, IE (Great Britain and Eire)**

This appliance has been certified for use in countries other than those stated. To install this appliance in these countries, it is essential to obtain the translated instructions and in some cases the appliance will require modification. Contact Dovre for further information.

#### **IMPORTANT**

**This product contains a Heat resistant glass panel. This panel should be checked during Installation and at each servicing interval. If any damage is observed on the front face of the glass panel (scratches, scores, cracks or other surface defects), the glass panel must be replaced and the appliance must not be used until a replacement is installed. Under no circumstances should the appliance be used if any damage is observed, the glass panel is removed or broken.**

**Parts of this appliance will become hot during operation; it is therefore recommended that a suitable guard should be used for protection of young children, the elderly or infirm.**

**This appliance is guaranteed for 2 years (subject to the conditions on page 3 of this Instruction manual). The second year of the guarantee will only be valid if the annual service recommended in this Instruction manual has been completed by a GasSafe registered engineer, and a copy of the service report is available for inspection by a Gazco engineer.**

**These Instructions must be left with the appliance for future reference and for consultation when servicing the appliance. Please make the customer aware of the correct operation of the appliance before leaving these instructions with them.**

**The commissioning sheet found on Page 3 of this Instruction manual must be completed by the Installer prior to leaving the premises.**

# CONTENTS

## COVERING THE FOLLOWING MODELS

DV-280BFNG  
DV-280BFLPG

	<b>PAGE</b>
<b>APPLIANCE COMMISSIONING CHECKLIST</b>	<b>3</b>
<b>USER INSTRUCTIONS</b>	<b>4</b>
<b>INSTALLATION INSTRUCTIONS</b>	<b>10</b>
Technical Specifications	10
Site Requirements	11
Installation	15
Commissioning	22
<b>SERVICING INSTRUCTIONS</b>	<b>23</b>
Servicing Requirements	23
Fault Finding	23
How to replace parts	25
Basic spare parts list	28
Service Records	29

# APPLIANCE COMMISSIONING CHECKLIST

## IMPORTANT NOTICE

Explain the operation of the appliance to the end user, hand the completed instructions to them for safe keeping, as the information will be required when making any guaranteed claims.

FLUE CHECK	PASS	FAIL
1. Flue is correct for appliance		
2. Flue flow test N/A		
3. Spillage test N/A		
GAS CHECK		
1. Gas soundness & let by test		
2. Standing pressure test	mb	
3. Appliance working pressure (on High Setting) NB All other gas appliances must be operating on full	mb	
4. Gas rate	m <sup>3</sup> /h	
5. Does ventilation meet appliance requirements		
6. Have controls been upgraded (Upgradeable models only)	8455 Standard YES	NO
	8456 Programmable Thermostatic and Timer YES	NO

## RETAILER AND INSTALLER INFORMATION

Retailer .....

.....

.....

Contact No. ....

Date of Purchase .....

Model No. ....

Serial No. ....

Gas Type .....

Installation Company .....

.....

.....

Engineer .....

Contact No. ....

Gas Safe Reg No. ....

Date of Installation .....

This product is guaranteed for 2 years from the date of installation, as set out in the terms and conditions of sale between Dovre and your local Dovre retailer. **This guarantee will be invalid, to the extent permitted by law, if the above Appliance Commissioning Checklist is not fully completed by the installer and available for inspection by a Dovre engineer.** The guarantee will only be valid during the second year, to the extent permitted by law, if the annual service recommended in the Instructions for Use has been completed by a Gas Safe registered engineer, and a copy of the service visit report is available for inspection by a Dovre engineer.

# USER INSTRUCTIONS

## 1. GENERAL

**In the event of a gas escape or if you can smell gas, please take the following steps:**

- Immediately turn off the gas supply at the meter/emergency control valve.
- Extinguish all sources of ignition.
- Do not smoke.
- Do not operate any electrical light or power switches (On or Off).
- Ventilate the building(s) by opening doors and windows.
- Ensure access to the premises can be made.

Please report the incident immediately to the National Gas Emergency Service Call Centre on 0800 111 999 (England, Scotland and Wales) 0800 002 001 (N. Ireland) or in the case of LPG, the gas supplier whose details can be found on the bulk storage vessel or cylinder.

**The gas supply must not be used until remedial action has been taken to correct the defect and the installation has been recommissioned by a competent person.**

- 1.1 Installation and servicing must only be carried out by a competent person whose name appears on the Gas Safe register. To ensure the engineer is registered with Gas Safe they should possess an ID Card carrying the following logo:



- 1.2 In all correspondence, please quote the appliance Model and Serial Number which can be found on the data badge at the rear of the appliance.
- 1.3 Do not place curtains above the appliance. You must leave 300mm (1') clearance between the appliance and any curtains at either side.
- 1.4 If you see any cracks in the glass panel, do not use the appliance until the glass has been replaced.
- 1.5 If the flue has to be removed from the appliance for any reason, the seals must be replaced in the inner spigot.
- 1.6 Do not obstruct the flue terminal in any way, i.e. by planting flowers, trees, shrubs etc. in the near vicinity, or by leaning objects against the terminal guard.
- 1.7 Do not put any objects on the terminal guard; it will lose its shape.
- 1.8 If you use a garden sprinkler, do not let quantities of water into the flue terminal.

- 1.9 There is a two year guarantee from the date of installation of this appliance as set out in the Terms and Conditions of Sale between Dovre and your local Dovre retailer. Consult your local retailer if you have any questions and quote the Model and Serial Number. Please make sure the *Appliance Commissioning Checklist* is completed by your installer; it is a requirement of your Guarantee.
- 1.10 All the outer-casing of this appliance is considered by the manufacturer to be a working surface which becomes hot when the appliance is lit. You must use a suitable fire guard to protect children the elderly and infirm.

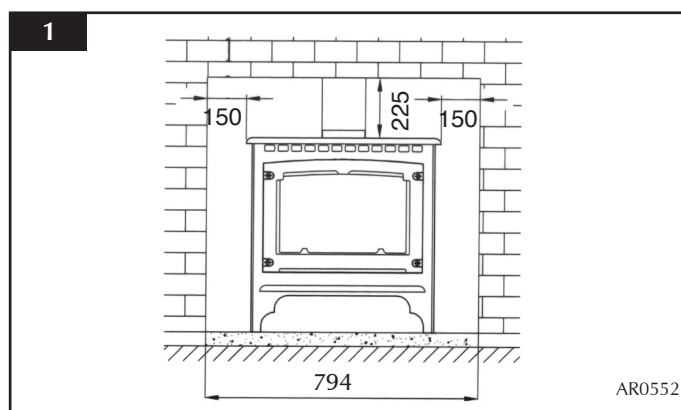

## 2. LIGHTING THE APPLIANCE

- 2.1 The control valve is at the foot on the right-hand side of the appliance. It has two controls:
- The right-hand knob controls the pilot ignition.
  - The left-hand knob controls the main burner.
- 2.2 Refer to separate instructions if your appliance is upgraded to include battery remote control. The instructions below apply whether or not you have the remote upgrade.

### Lighting the Pilot

- 2.3 The left-hand and right-hand control knobs must both point to off (●):

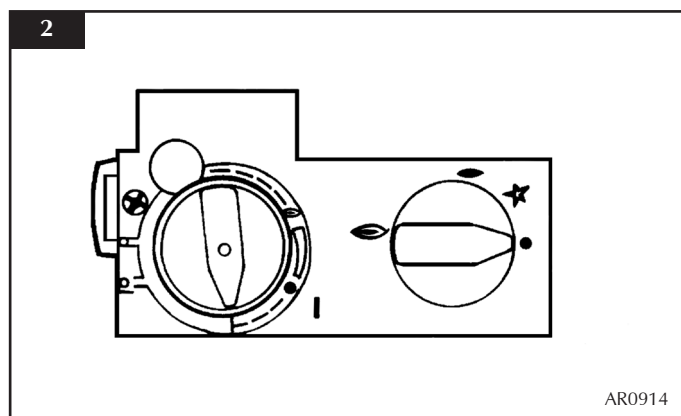

# USER INSTRUCTIONS

- 2.4 Press in the right-hand control knob and rotate anti-clockwise until a click is heard.
- 2.5 Continue to press in. The knob should point to the pilot (←). The pilot should now light.
- 2.6 Keep the knob depressed for 10 seconds before releasing. The pilot should remain lit.
- 2.7 If the pilot does not stay lit repeat the above steps.

**NOTE: If the pilot goes out the Interlock system prevents it being lit again for a short period.**

- 2.5 If, after repeating the above steps, the pilot does not light, contact your retailer or installer.

## Adjusting the Flame height

- 2.6 Turn the right hand control to point to main burner (→). You can now adjust the flame height and temperature using the left-hand control knob.
- 2.7 Turn the left-hand knob anti-clockwise to increase the flame height.
- 2.8 Turn clockwise to decrease the height.

**YELLOW FLAMES APPEAR WHEN THE APPLIANCE HAS REACHED SUFFICIENT HEAT (10 TO 20 MINUTES). IF THE APPLIANCE IS EXTINGUISHED OR GOES OUT DURING USE WAIT 3 MINUTES BEFORE ATTEMPTING TO RELIGHT.**

## 3. TURNING THE APPLIANCE OFF

- 3.1 To turn off main burner turn the **left-hand** knob until it points to off (●). The pilot light will remain lit.
- 3.2 To turn off pilot light press in and turn the **right-hand** knob until it points to off (●). The pilot light will go out.

## 4. UPGRADING THE APPLIANCE

The appliance is fitted with a control valve that can be upgraded to support a battery powered remote control. Two types of remote control can be obtained through your local Gazco stockist:

- 4.1 The **Standard Remote Control (Gazco Part No. 8455)** controls the appliance after the pilot is lit so you can regulate the main burner through its range of settings and turn the burner off leaving just the pilot lit.
- 4.2 The **Thermostatic and Timer Remote Control (Gazco Part No. 8456)** controls the appliance after the pilot is lit using three modes:
  - Manual Mode – used to turn the burner on and off and regulate it through its range of settings.
  - Auto Mode – used to turn the burner on and off and regulate the heat to a pre-set temperature.
  - Timer Mode – used to turn the burner on and off at two pre-set times and regulate the heat to a pre-set temperature during those periods.

## 5. CLEANING THE APPLIANCE

### ADVICE ON HANDLING AND DISPOSAL OF FIRE CERAMICS

- 5.1 The fuel effect logs and embers in this appliance are made from Refractory Ceramic Fibre (RCF). Protective clothing is not required when handling these articles, but we recommend you follow normal hygiene rules of not smoking, eating or drinking in the work area and always wash your hands before eating or drinking. Excessive exposure to these materials may cause temporary irritation to eyes, skin and respiratory tract; wash hands thoroughly after handling the material.
- 5.2 To ensure that the release of RCF fibres is kept to a minimum a HEPA filtered vacuum is recommended to remove any dust accumulated in and around the appliance.
- 5.3 When servicing the appliance it is recommended that the replaced items are not broken up, but are sealed into heavy duty polythene bags and labelled as RCF waste. RCF waste is classed as stable, non-reactive, hazardous waste and may be disposed of at a licensed landfill site.
- 5.4 After cleaning the appliance or replacing parts, carefully re-assemble the ceramic components.

**WHEN THE EMBERS ARE PLACED ON THE BURNER IT IS IMPORTANT THEY DO NOT COVER ANY PORTS!**

**WARNING: NEVER CLEAN THE APPLIANCE WHILE IT IS HOT. THE APPLIANCE STAYS HOT FOR A LONG TIME AFTER SHUTDOWN.**

- 5.5 Make sure the appliance and surrounds are cool before trying to clean.

# USER INSTRUCTIONS

## REMOVING THE DOOR

5.6 To remove the door on the rear exit applications:  
Lift the top of the appliance off and put to one side.

5.7 For top exit:

Lift and support the top to give clearance (see Diagram 3).

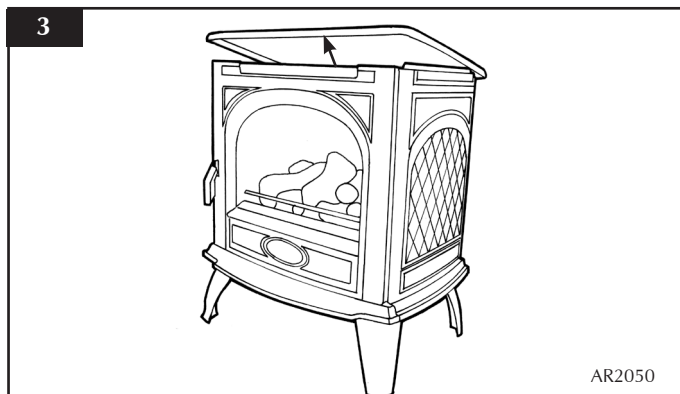

5.8 Lift the front upwards until it is clear of the slots.

5.9 Pull towards you away from the appliance (see Diagram 4).

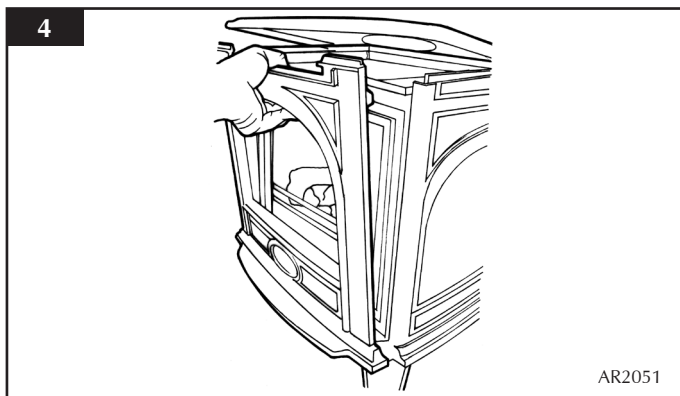

5.10 Remove the glass frame by undoing the frame fixing screws and lifting clear (see Diagram 5).

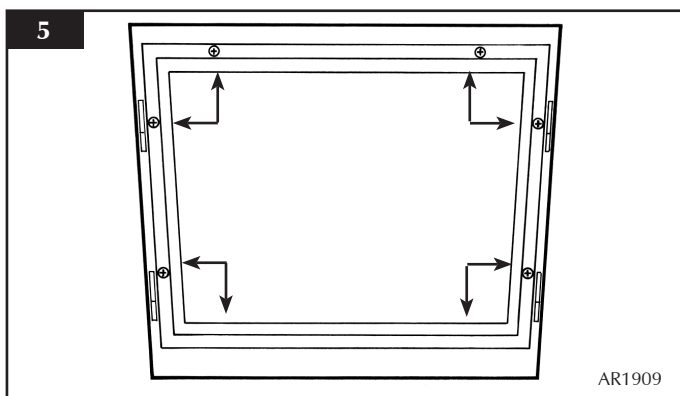

5.11 The ceramic logs and embers should not need cleaning.  
Do not use a vacuum cleaner or brush to clean the logs.

5.12 Lift out the log retainer bar (see Diagram 8).

5.13 Remove all the ceramic logs and embers from inside the appliance. The embers are lightweight black flakes.

5.14 Remove any large pieces of debris by hand.

5.15 Remove any debris from the burner ports.

5.16 Replace the logs and embers as set out in Section 6.

5.17 Use a damp cloth to clean the outer casing of the appliance.

## 6. FUEL BED ARRANGEMENT

**WHEN THE EMBERS ARE PLACED ON THE BURNER IT IS IMPORTANT THEY DO NOT COVER ANY PORTS.**

The fuel bed is made up of embers and 6 logs, identifiable by molded letters.

6.1 Place Log A on the ledge at the rear of the appliance (see Diagram 6).

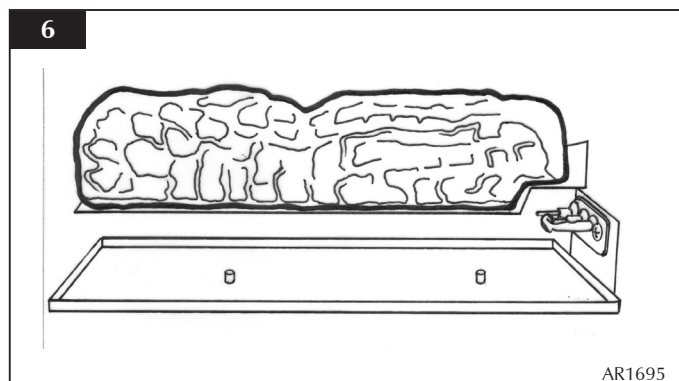

6.2 Place Log C onto the two studs on the burner skin (see Diagram 6A) with charred effect of the log facing forward (see Diagram 6B).

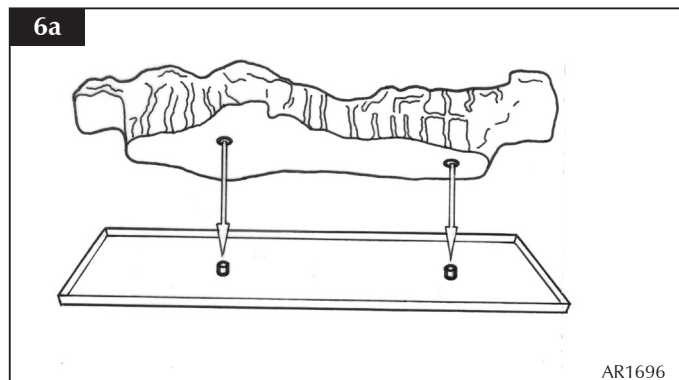

# USER INSTRUCTIONS

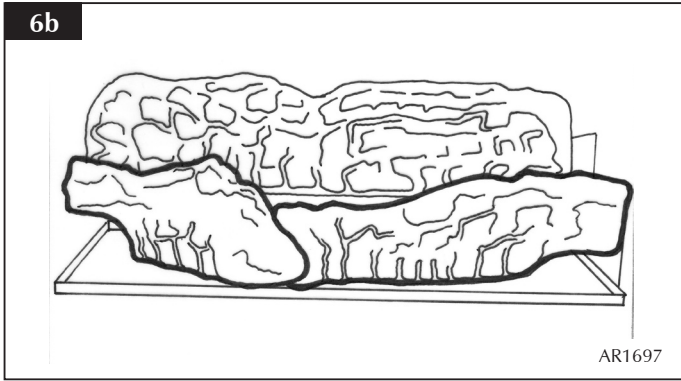

- 6.3 Put the embers on the burner around the positioned logs. **TAKE CARE NOT TO COVER ANY PORTS ON THE BURNER** as shown in Diagram 7.

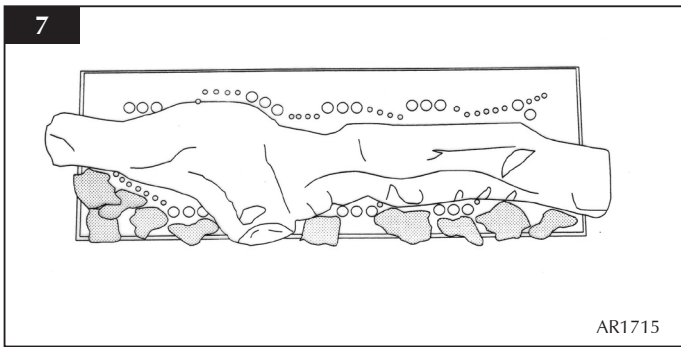

- 6.4 Place the log retainer in the two guides as shown (see Diagram 8).

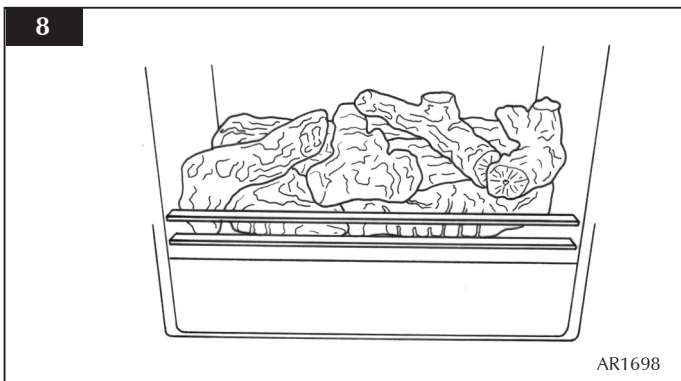

**FOR CLARITY, THE FOLLOWING LOG ARRANGEMENT DIAGRAMS DO NOT INCLUDE ILLUSTRATION OF THE RETAINER.**

- 6.5 Place Log D so that the back end sits in the groove in the rear of Log A (see Diagram 8A) and the front left rests in the groove in Log C (see Diagram 8B).

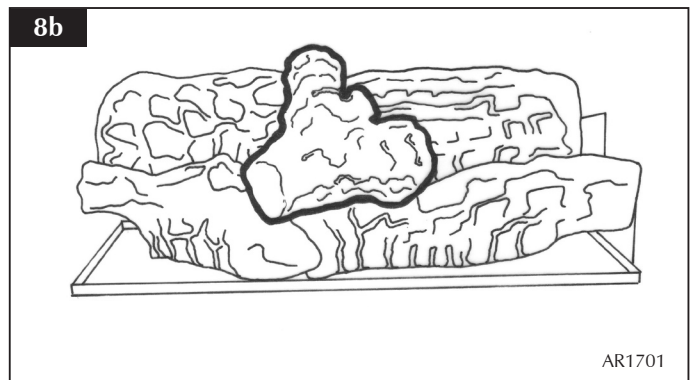
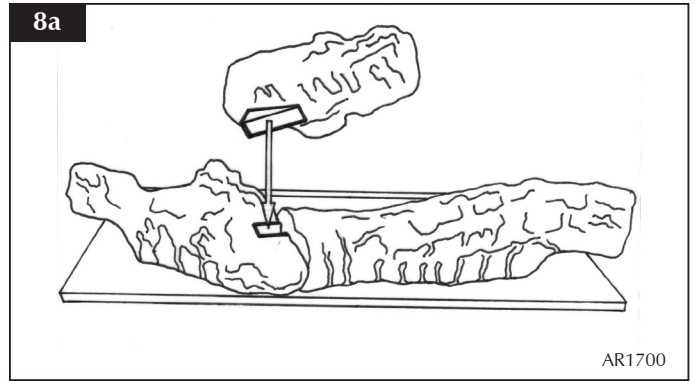

- 6.6 Position Log B so that the underneath rests in the groove of Log C (see Diagram 9A) and the end is in the corner of the burner (see Diagram 9B).

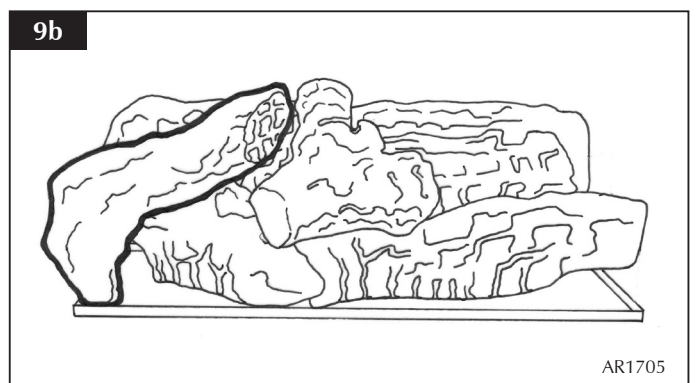
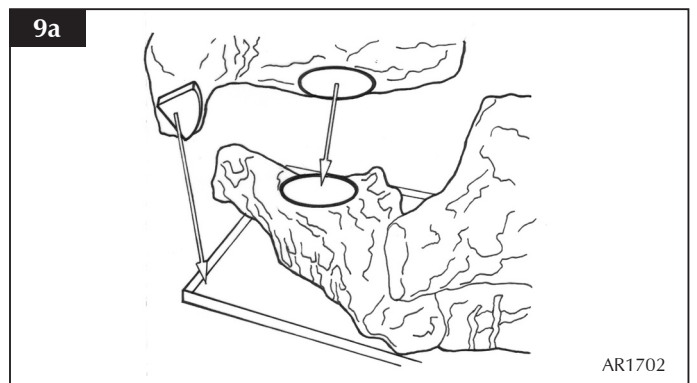

# USER INSTRUCTIONS

- 6.7 Place the groove underneath Log F over Log C (see Diagram 10A) so that F is parallel to the side of the firebox (see Diagram 10B).

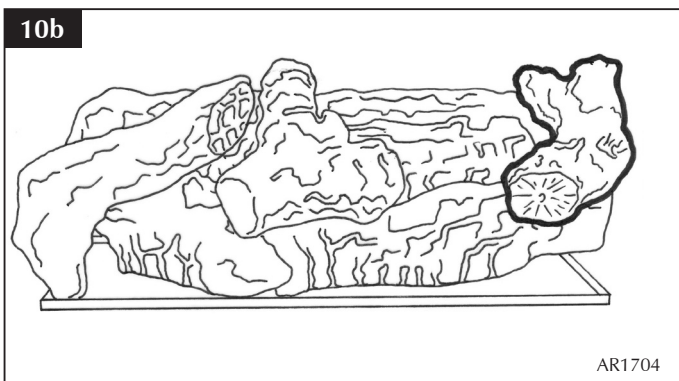
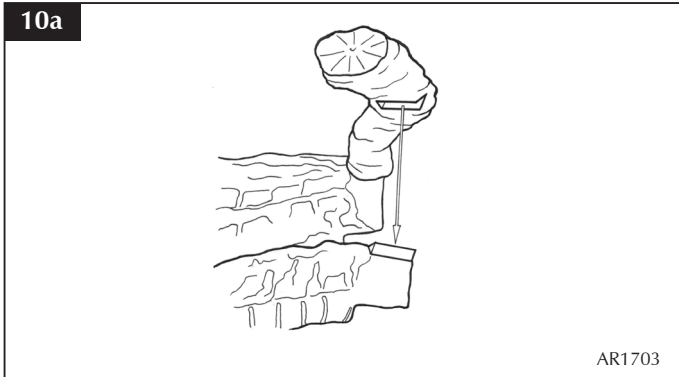

- 6.8 Place Log E into the groove between Log F and Log D (see Diagram 11A) so that it rests across logs A and D (see Diagram 11B).

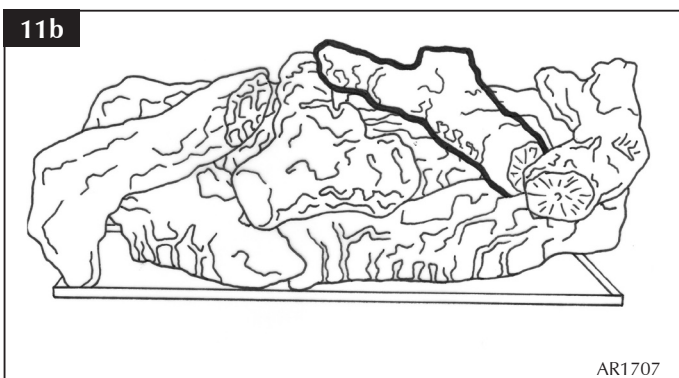
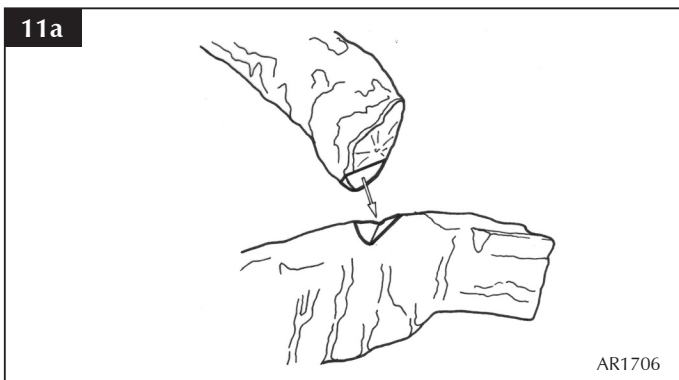

## 7. REPLACING THE DOOR

- 7.1 Ensure the rope seal on the rear of the glass frame is intact. If broken or worn, contact your Dovre retailer for a replacement.
- 7.2 Use a ceramic glass product generally sold for cleaning ceramic hobs to clean the glass front.
- 7.3 Refit glass frame and tighten screws evenly.

**NEVER OPERATE THE Appliance WHEN THE GLASS FRAME IS REMOVED OR THE GLASS IS BROKEN.**

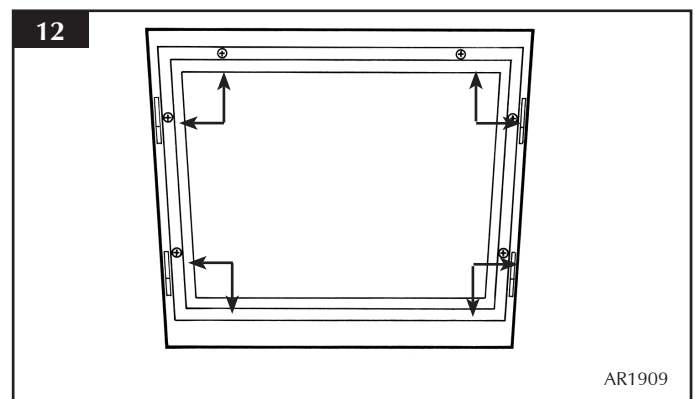

- 7.2 With the top still supported or removed refit front by locating in grooves and lowering into place.

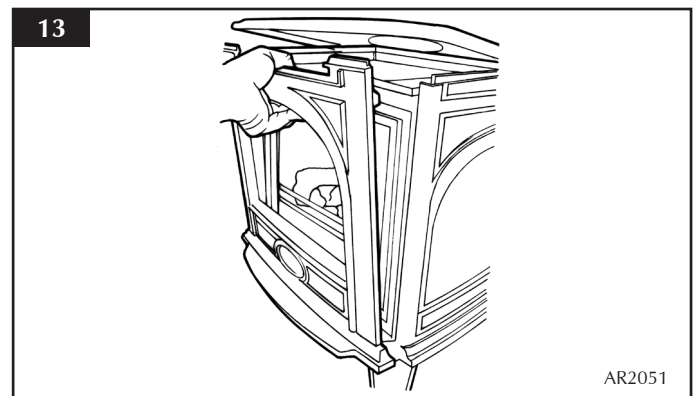

- 7.3 Replace top.

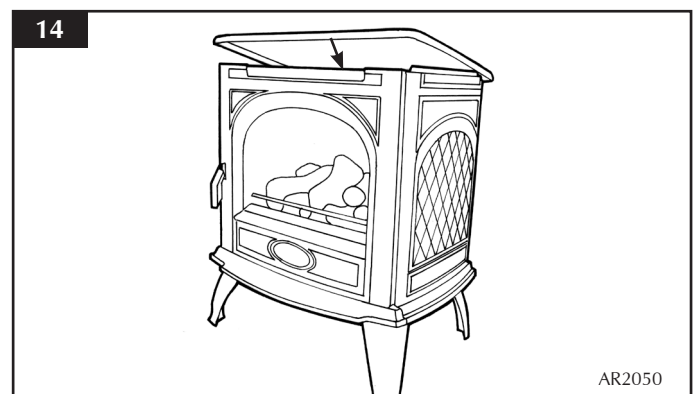

# USER INSTRUCTIONS

## 8. THE FLAME FAILURE DEVICE

This safety feature of all Dovre appliances automatically switches off the gas supply should the pilot go out.

## 9. 'RUNNING IN'

The surface coating of your Dovre appliances 'burns off' during the first few hours of use, producing a harmless temporary odour. This disappears after a short period. If it persists ask your retailer for advice.

## 10. SERVICING

A qualified gas engineer must service the appliance every 12 months. In all correspondence, always quote the Model and Serial Number that can be found on the data badge at the back of the appliance.

## 11. INSTALLATION DETAILS

Make sure your installer completes the *Appliance Commissioning Checklist* on page 3. This records essential details of this appliance. In all correspondence, always quote the Model and Serial Number (see Section 10 above).

## 12. HOT SURFACES

You must use a suitable fire guard to protect children, the elderly and the infirm as some parts of this appliance become hot during normal use.

# INSTALLATION INSTRUCTIONS

## TECHNICAL SPECIFICATION

DV-280BFNG  
DV-280BFLPG

MODEL	GAS CAT.	GAS TYPE	PRESSURE	NO <sub>x</sub>	AERATION	INJECTOR	GAS RATE m <sup>3</sup> /h	INPUT kW (Gross)		COUNTRY
								High	Low	
DV-280BFNG	I <sub>2</sub> H	Natural Gas G20	20mbar	4	6 x 15	158	0.398	4.25	3	UK, IE
DV-280BFLPG	I <sub>3</sub> P	LPG Propane G31	37mbar	3	6 x 10 (1) 16 x 23 (1)	110	0.146	4.1	2.6	UK, IE
Rear Exit	Wall Thickness									
	MIN MAX	200mm 550mm								
Efficiency Class 1										
Flue Outlet Size ø 150mm, Flue Inlet Size ø 100mm										
Gas Inlet Connection Size ø 8mm										
RESTRICTOR REQUIREMENT										
VERTICAL & HORIZONTAL FLUE Specification										
Vertical Flue Height from Top of Appliance				Horizontal Length			Restrictor Size			
500mm up to 1490mm				250mm up to 1000mm			No restrictor			
1500mm up to 300mm				250mm up to 5000mm			ø 75mm			
TOP EXIT - VERTICAL ONLY INCLUDING OFFSET										
Vertical Flue Height from Top of Appliance				Restrictor Size						
3000mm up to 4990mm				ø 52mm						
5000mm up to 10,000mm				ø 47mm						

### Packing Checklist

#### Qty Description

- 1 Appliance
- 1 Flue infill plate
- 1 Log set
- 1 Fixing kit containing
- 1 Instruction manual
- 2 Wood screws
- 2 Rawlplugs
- 1 Allen key

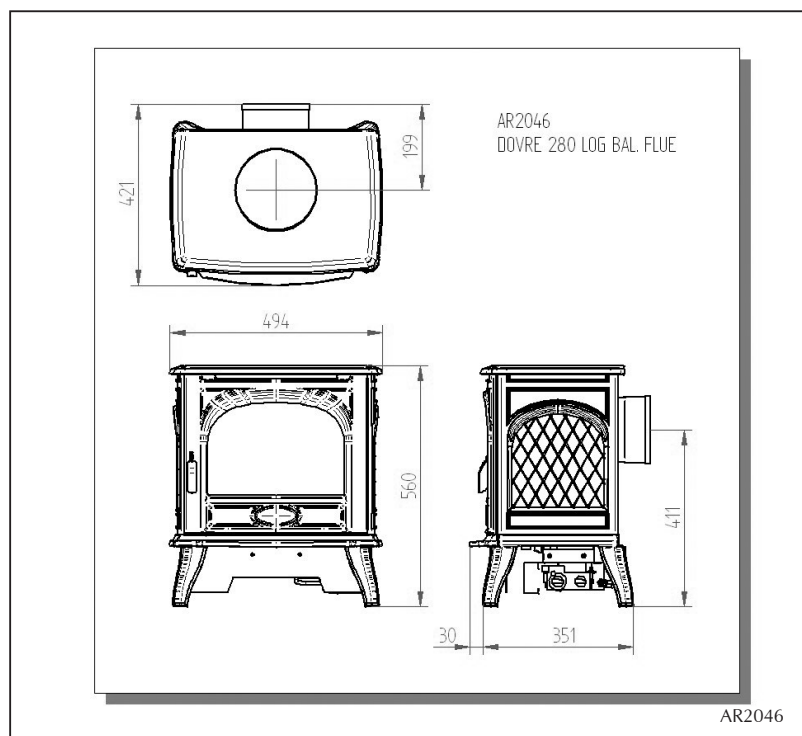

# INSTALLATION INSTRUCTIONS

## SITE REQUIREMENTS

### 1. FLUE AND CHIMNEY REQUIREMENTS

**Note: This appliance must be installed in conjunction with the flue supplied.**

- 1.1 The flue must be sited in accordance with BS5440:Part1 (latest edition) (see Diagram 1).
- 1.2 A guard must be fitted where the flue terminal exits at less than 2 metres above any level ground, balcony or flat roof to which people have access.
- 1.3 All vertical and horizontal flues must be securely fixed and conform to local and national codes of practice for fire precautions.
- 1.4 A restrictor may be required. Refer to the Technical Specifications on the previous page.

### 2. TIMBER FRAMED BUILDINGS

- 2.1 To prevent a fire hazard, you must provide additional clearance when the appliance passes through a wall containing any combustible materials.
- 2.2 A steel sleeve must be inserted into the hole through which the flue passes to give an air gap of 25mm between the sleeve and any outside surface of the flue.
- 2.3 Contact your local buildings authority for further guidance on installing gas fires in timber framed buildings.

**Note: Make sure you provide adequate clearance at the sides and back of the appliance for servicing access.**

1

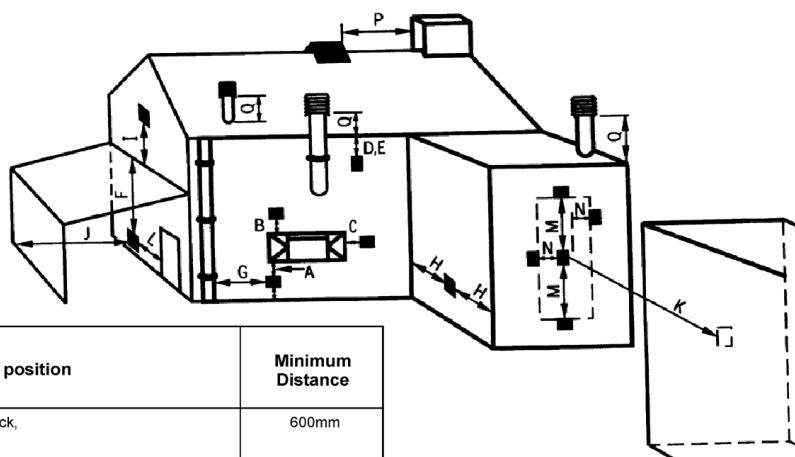

Dimension	Terminal position	Minimum Distance
A*	Directly below an opening, air brick, opening windows, etc.	600mm
B*	Above an opening, air brick opening windows, etc.	300mm
C*	Horizontally to an opening, air brick opening windows etc.	400mm
D	Below gutters, soil pipes or drain pipe	300mm
E	Below eaves	300mm
F	Below balconies or car port roof	600mm
G	From a vertical drain pipe or soil pipe	300mm
H	From an internal or external corner	600mm
I	Above group roof or balcony level	300mm
J	From a surface facing the terminal (also see 6.1.2)	600mm
K	From a terminal facing the terminal	600mm
L	From an opening in the car port (e.g. door, window) into the dwelling	1200mm
M	Vertically from a terminal on the same wall	1500mm
N	Horizontally from a terminal on the same wall	300mm
O	From the wall on which the terminal is mounted	N/A
P	From a vertical structure on the roof	600mm
Q	Above intersection with roof	300mm

\* In addition, the terminal should not be nearer than 300mm to an opening in the building fabric formed for the purpose of accommodating a built-in element such as a window frame

AR0602

# INSTALLATION INSTRUCTIONS

## SITE REQUIREMENTS

### 3. REAR FLUE

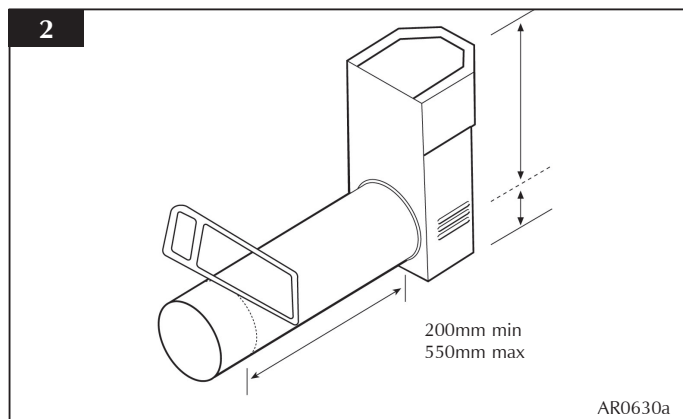

Terminal dimensions:  
395 x 200 x 200 mm (H x W x D)  
Guard supplied  
Cut to length as required on site (see Diagram 2).

### 4. TOP EXIT

There are two types of flue terminal: horizontal and vertical.  
For vertical see *Section 7* on page 13.

#### For horizontal:

- 4.1 Decide on the terminal position.
- 4.2 Measure the height from the top of the appliance to the centre of the required hole. For minimum and maximum dimensions see Diagram 3.
- 4.3 To fit the flue you must have access to the top or the side of the appliance to connect the flue.
- 4.4 Assemble the vertical sections.
- 4.5 Add the 90° elbow.
- 4.6 Add the horizontal section and terminal. **Only the horizontal part can be reduced in size.**
- 4.7 A masonry installation requires the addition of a suitable lintel to support the opening. Refer to *Installation Instructions, Technical Information* for details of the flue length.

### 5. TOP FLUE UP AND OUT KIT

This flue rises vertically from the top of the appliance, then continues horizontally outward (see Diagram 3).

The basic kit comprises:  
1 x 500mm vertical length  
1 x 500mm terminal length  
1 x 90 degree elbow  
1 x wall plate  
1 x 75mm restrictor fixing screws

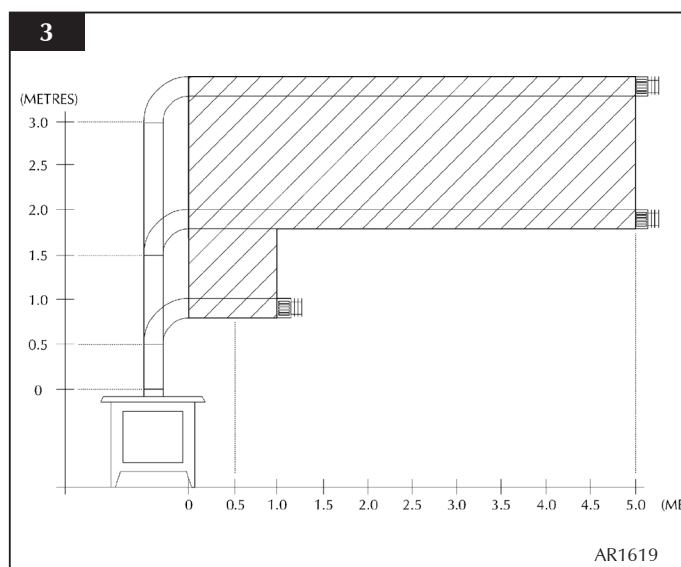

- 5.2 This kit provides the minimum materials. Extra lengths can be added to the vertical and horizontal sections; refer to *Section 7*.
- 5.3 Refer to *Installation Instructions, Technical Specification* (page 10) to identify when to use a restrictor.

# INSTALLATION INSTRUCTIONS

## SITE REQUIREMENTS

### 6. TOP FLUE UP AND OUT WITH ADDITIONAL BEND

An additional bend can be used on the horizontal section (45° or 90°) but the overall horizontal flue is reduced. (see Diagram 4).

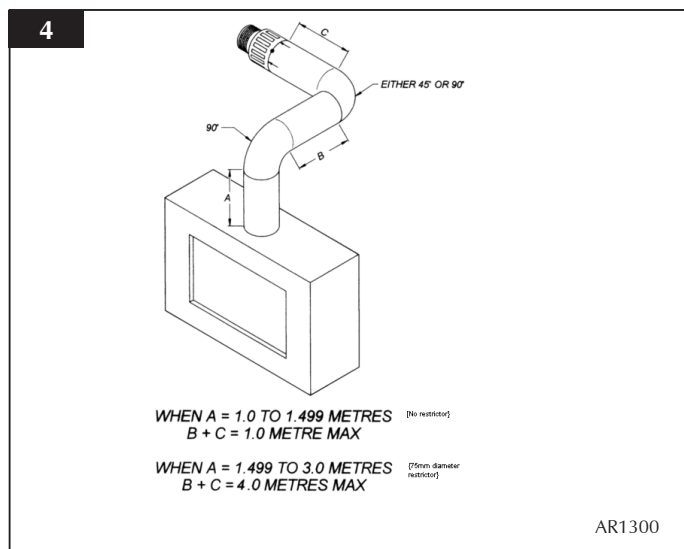

### 7. TOP FLUE VERTICAL OFFSET KIT

- 7.1 This flue is vertical from the top of the appliance (see Diagram 5). A minimum vertical rise of 3m (9'10") to a maximum of 10m (32'10").

The basic kit comprises:

- 2 x 1m lengths
- 1 x 1m terminal lengths
- 1 x 52mm restrictor (sliding plate assembly)
- 1 x 47mm restrictor (sliding plate assembly)

- 7.2 Extra lengths can be added (see Diagram 5).

- 7.3 Refer to *Installation Instructions, Technical Specification* (page 9) to identify when to use a restrictor.

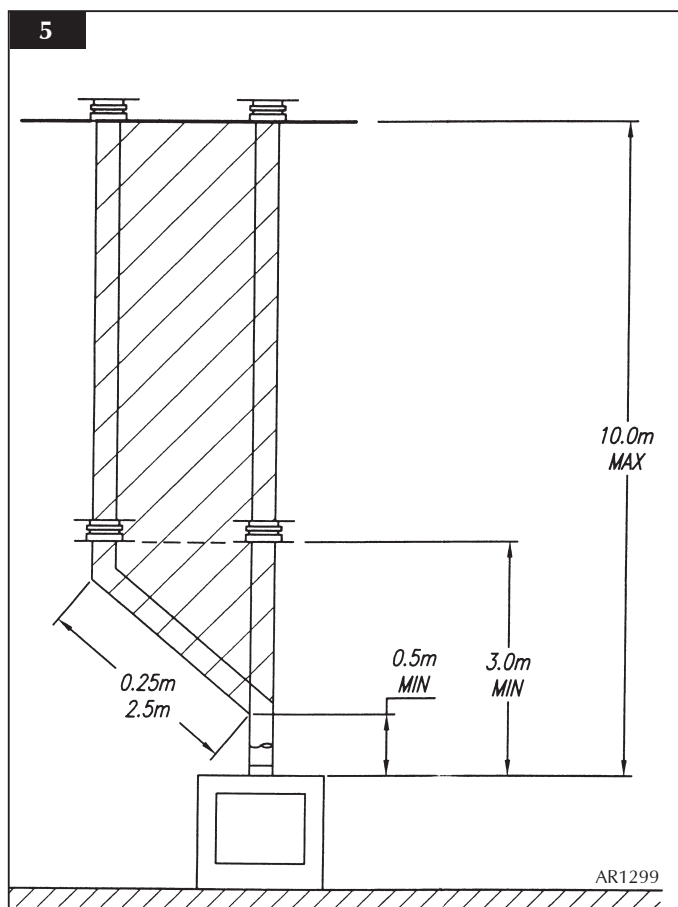

### 8. OPTIONAL EXTRA FLUE LENGTHS AND BENDS

Nominal Length	Actual Length	Stainless Finish	Anthracite Finish
200mm	140mm	8527	8527AN
500mm	440mm	8528	8528AN
1000mm	940mm	8507	8507AN
40° Bend	N/A	8507	8507AN
90° Bend	N/A	8508	8508AN
Optional Flue Collar (Appliances Only)		N/A	8548

# INSTALLATION INSTRUCTIONS

## SITE REQUIREMENTS

### 9. INSTALLATION OF THE GAS SUPPLY

- 9.1 Before installation ensure the appliance is compatible with the local gas type and pressure.
- 9.2 Ensure the gas supply delivers the required amount of gas in accordance with the rules in force.
- 9.3 Soft copper tubing and soft soldered joints must be no closer than 50mm to the base of the burner unit.
- 9.4 Ensure there is a means of isolating the gas supply **independent of the appliance's controls.**
- 9.5 All gas supply pipes must be purged of any debris before connection to the appliance.

### 10. APPLIANCE LOCATION

- 10.1 This appliance must stand on a non-combustible hearth that is at least 12mm thick and projects 50mm minimum from the base of the appliance in all directions (see Diagram 6).

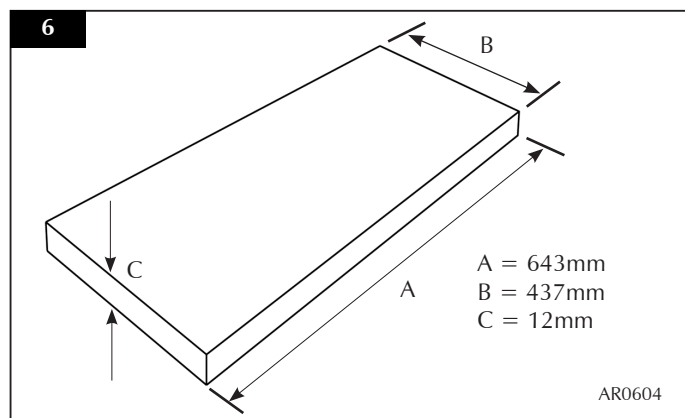

#### MINIMUM CLEARANCE

- 10.2 The appliance is not suitable for installation against a combustible wall. All combustible materials must be removed from behind the appliance.
- 10.3 Ensure that all minimum clearances to combustible materials are complied with (see Diagrams 7 and 8).

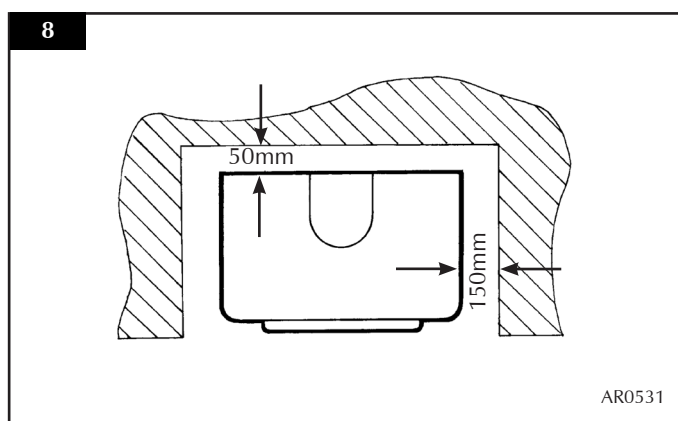
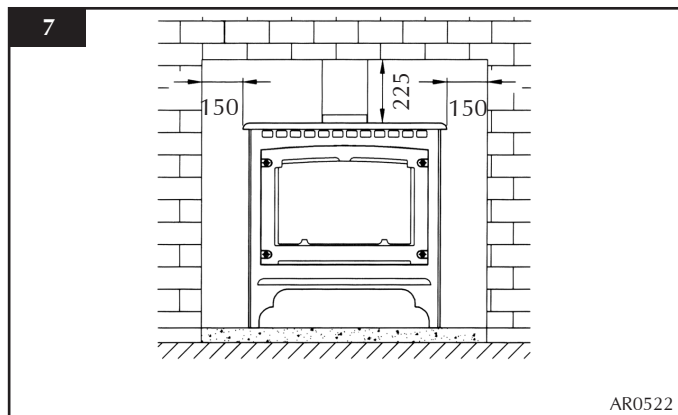

- 10.4 The above dimensions provide adequate clearance to combustible materials. It may be necessary to add additional clearance so that the controls can be reached and spillage tests performed when necessary.

# INSTALLATION INSTRUCTIONS

## INSTALLATION

**IMPORTANT: MAKE SURE THE APPLIANCE IS ADJUSTED FOR THE GAS TYPE AND CATEGORY IN ITS COUNTRY OF USE. REFER TO THE DATA BADGE AND TECHNICAL SPECIFICATION PAGE. FOR DETAILS OF CHANGING BETWEEN GAS TYPES REFER TO THE *REPLACING PARTS SECTION, CHANGING BETWEEN GAS TYPES.***

### 1. SAFETY PRECAUTIONS

- 1.1 This appliance must be installed in accordance with the rules in force. Read these instructions before installing the appliance.
- 1.2 All the instructions must be left, intact, with the user.
- 1.3 In the interests of your own and other's safety, this appliance must be installed by a competent person according to local and national codes of practice. Failure to install the appliance correctly could lead to prosecution.
- 1.4 This appliance is for use on a governed gas installation and set to the required pressure.
- 1.5 Keep all plastic bags away from young children.
- 1.6 Do not place any object on or near the appliance. Leave adequate clearance above the appliance (see *Site Requirements, Section 10*).

### 2. CONTROL UPGRADE

- 2.1 The appliance is fitted with a control valve that can be upgraded to support a battery powered remote control. Two types of remote control can be obtained through your local Gazco stockist:
- 2.2 This upgrade can be fitted before or after installation, but, if side clearances are limited, it will be easier to upgrade the appliance before installation. Full instructions are included with the kit.
- 2.3 The **Standard Remote Control (Gazco Part No. 8455)** controls the gas appliance after the pilot is lit so you can regulate the main burner through its range of settings and turn the burner off leaving just the pilot lit.
- 2.4 The **Thermostatic and Timer Remote Control (Gazco Part No. 8456)** controls the appliance after the pilot is lit using three modes:
  - Manual Mode – used to turn the burner on and off and regulate it through its range of settings.
  - Auto Mode – used to turn the burner on and off and regulate the heat to a pre-set temperature.
  - Timer Mode – used to turn the burner on and off at two pre-set times and regulate the heat to a pre-set temperature during those periods.

### 3. INSTALLATION OF THE APPLIANCE

**NOTE: THE CAST IRON DOOR IS HEAVY, TAKE GREAT CARE WHEN HANDLING TO AVOID DAMAGING THE OUTER CASING.**

#### REMOVING THE DOOR

- 3.1 To remove the door on the rear exit applications lift the top of the appliance off and put to one side.
- 3.2 For top exit lift and support the top to give clearance (see Diagram 1).

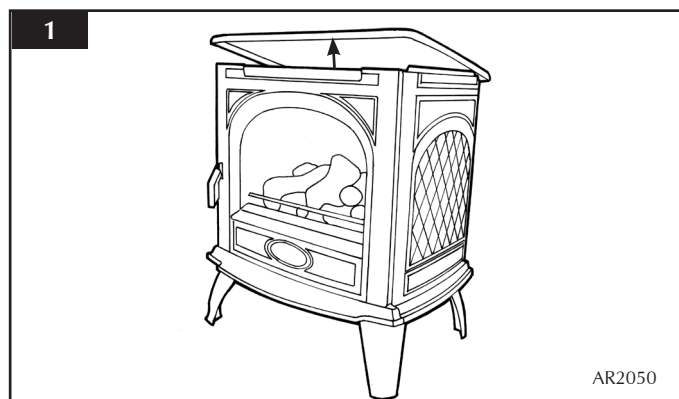

- 3.3 Lift the front upwards until it is clear of the slots.
- 3.4 Pull towards you away from the appliance (see Diagram 2).

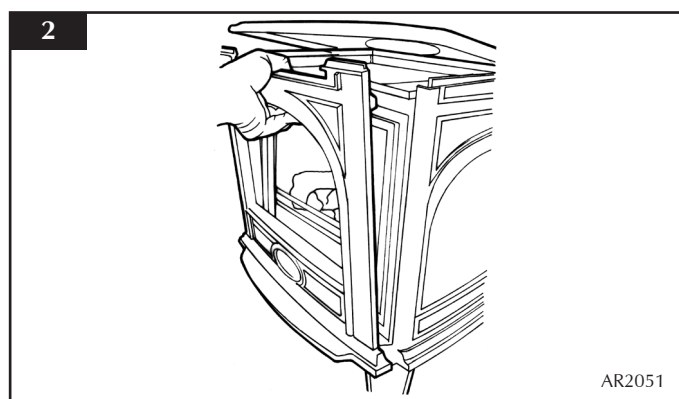

# INSTALLATION INSTRUCTIONS

## INSTALLATION

- 3.5 Remove the glass frame by undoing the frame fixing screws and lifting clear (see Diagram 3).

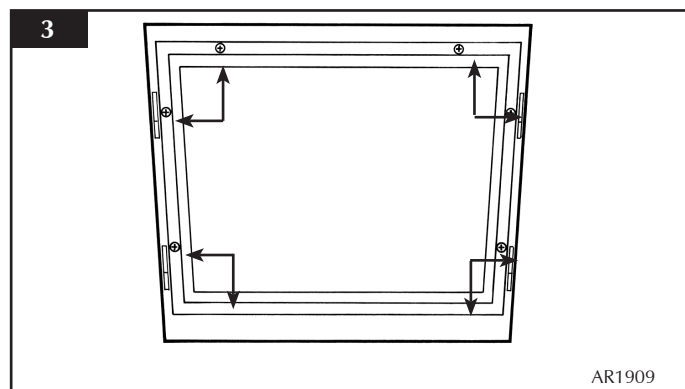

- 3.6 **REFER TO SITE REQUIREMENTS FOR ALL FLUE OPTIONS.**

This appliance is suitable for TOP or REAR flue exit.

### REAR FLUE EXIT

- 3.7 **Wall thickness:**     **MIN = 200mm**  
                                      **MAX = 550mm**
- 3.8 Unpack the adjustable flue assembly and terminal guard.
- 3.9 Do not lose the fixings.
- 3.10 Consider the final appliance position ensuring you comply with clearances required for the external flue, see *Site Requirements, Section 1*.
- 3.11 Mark the vertical centre-line of the appliance on the wall (see Diagram 4, A).
- 3.12 Mark the height from the top of the hearth to the centre of the flue (see Diagram 4, B).

**TAKE CARE TO MARK OUT THE FLUE CORRECTLY. IT IS DIFFICULT TO MOVE AFTER INSTALLATION.**

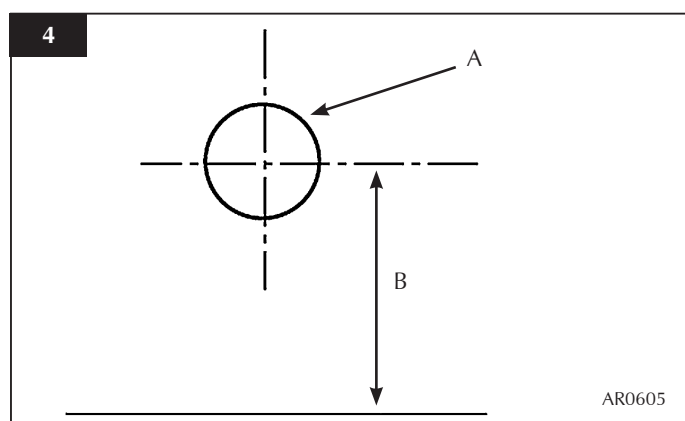

### Flue Aperture

- 3.13 Create a 152mm (6") diameter hole for the flue using either:

- a) a core drill, or
- b) a hammer and chisel

- 3.14 Make good at both ends of the hole.

### Flue Length

- 3.15 Measure the total wall thickness and add 65mm.
- 3.16 The total flue length gives a minimum clearance of 50mm between the rear of the appliance and the wall.
- 3.17 Insert the square cardboard sleeve into the flue to support the inner tube.
- 3.18 Cut through the flue and sleeve (see Diagram 5).

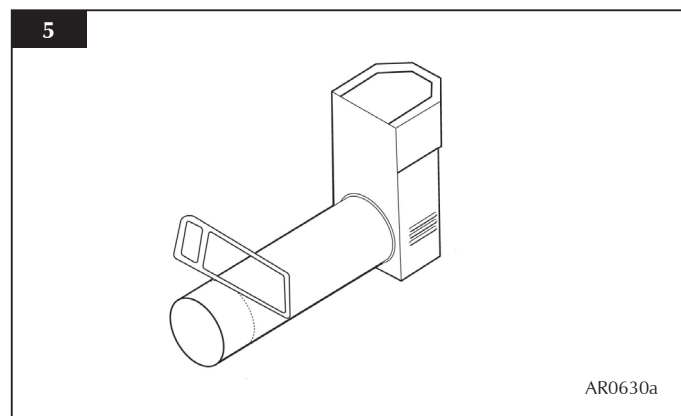

- 3.19 **REMOVE THE CARDBOARD REMNANTS FROM THE FLUE.**

- 3.20 File the cut edges smooth.

### Terminal

On the outside wall:

- 3.21 Position the flue assembly into the hole. The terminal should be flat against the wall.
- 3.22 Make sure the terminal is vertical (see Diagram 6).
- 3.23 Mark the four fixing holes.
- 3.24 Remove the terminal to drill the holes.
- 3.25 Insert wall plugs supplied.

**DO NOT FIX THE FLUE AT THIS STAGE.**

# INSTALLATION INSTRUCTIONS

## INSTALLATION

### Flue and Appliance Fixings

- 3.26 Position the appliance observing appropriate clearances.
- 3.27 Apply a bead of suitable weatherproof sealant (silicone or similar) to perimeter of back face of terminal (see Diagram 6, A).

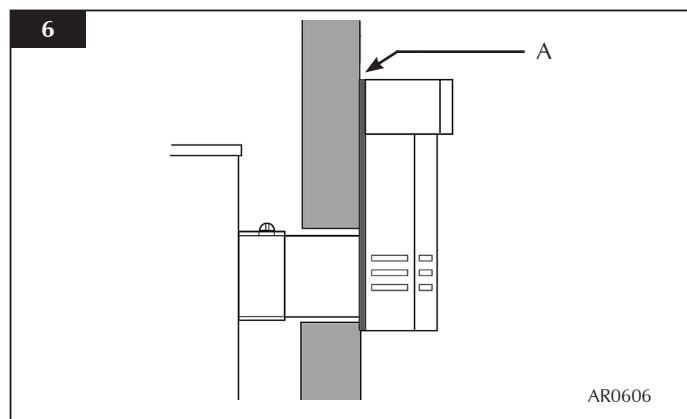

- 3.28 Feed the flue through the wall, making sure it runs smoothly.

On the inside wall:

- 3.29 Engage the flue in the inner and outer spigots.
- 3.30 Make sure rubber seals on the spigots are not damaged

From outside:

- 3.31 Insert four screws in the flanges of the flue terminal.
- 3.32 Check sealant has formed a water-tight joint to the wall.
- 3.33 Any terminal less than 2m above any access (level ground, balcony or flat roof with access) must be fitted with the guard supplied (see Diagram 7).

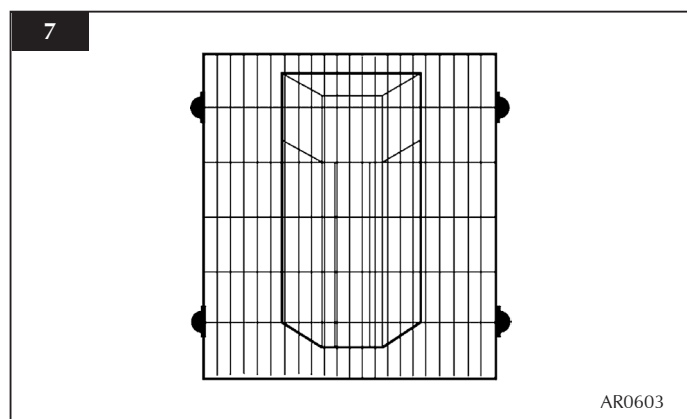

### TOP EXIT

- 3.34 There are two types of top exit flue terminals: vertical and horizontal (see *Site Requirements, Diagram 3*, for minimum and maximum flue lengths).

#### Decorative Cover

- 3.35 There is an optional decorative collar, Gazco Part No: 8548, to cover the gap between the top plate and flue.

**THIS MUST BE POSITIONED BEFORE INSTALLING THE FLUE. WHEN INSTALLING A TOP EXIT FLUE, REFER TO *INSTALLATION INSTRUCTIONS, TECHNICAL SPECIFICATION* (PAGE 10) FOR THE APPROPRIATE SIZE RESTRICTOR.**

#### Restrictors for flues with both Vertical and Horizontal Sections

Vertical Flue Height from Top of Appliance	Horizontal Length	Restrictor Size
500mm - 1490mm	250mm - 1000mm	No Restrictor
1500mm - 3000mm	250mm - 5000mm	75mm $\phi$

#### Reversing Spigots

- 3.36 The appliance is factory set for rear exit. For top exit reverse the spigots and blanking plates (see Diagram 8).

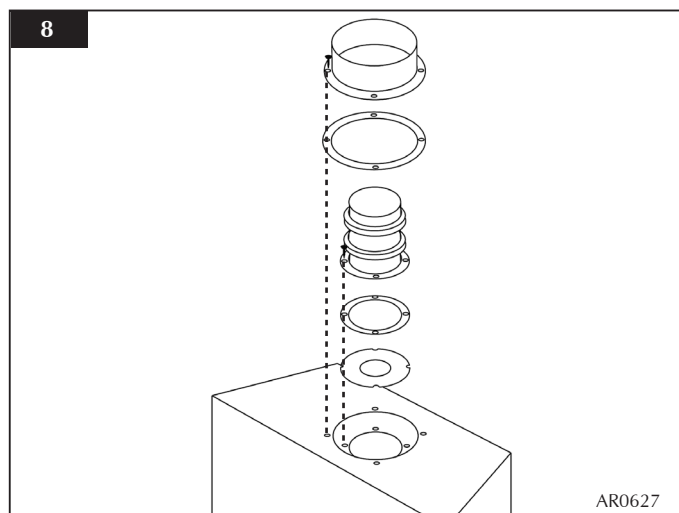

- 3.37 **REMEMBER TO FIT THE OPTIONAL DECORATIVE COLLAR IF REQUIRED.**

#### Wall Plate

- 3.38 A wall plate is supplied to secure the flue to the inside wall. Bend the securing tab to 90° and slot the plate over the flue before bringing the flue through the wall.
- 3.39 Mark the fixing holes using the wall plate as a template. The tab can be above or beneath the flue (see Diagram 9).

# INSTALLATION INSTRUCTIONS

## INSTALLATION

### Flue Aperture

- 3.40 Mark the height from the top of the hearth to the centre of the horizontal section (see Diagram 9).

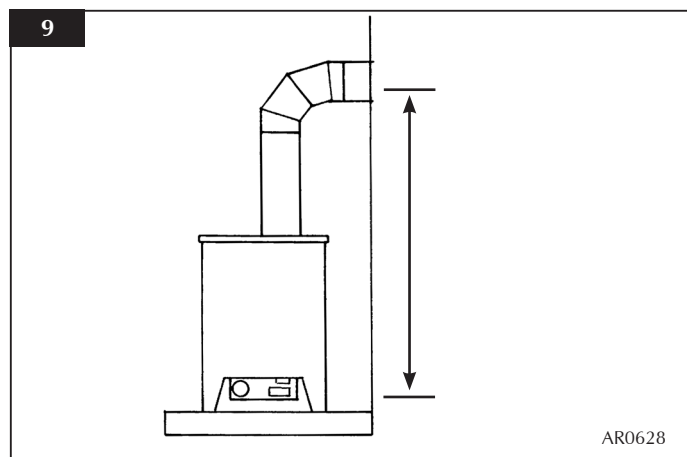

- 3.41 **TAKE CARE TO MARK OUT THE FLUE CORRECTLY. IT IS DIFFICULT TO MOVE AFTER INSTALLATION.**

- 3.42 Create a 152mm (6") diameter hole for the flue using either:
- a core drill, or
  - a hammer and chisel

- 3.43 Make good at both ends of the hole.

### Flue Length

- 3.44 The final length of the flue pipe includes the terminal. The terminal is the only section that can be shortened.

### DO NOT SHORTEN ANY OTHER SECTION OF FLUE PIPE.

- 3.45 Measure from the outside of the wall to the stop on the 90° elbow.
- 3.46 Fit horizontal flue section between the elbow and the terminal at this stage, if required (see Diagram 10).

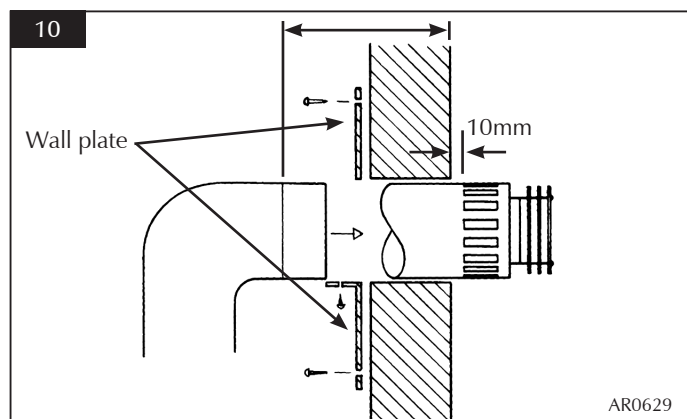

- 3.47 Mark the correct length all the way around the flue terminal section (see Diagram 10).

- 3.48 Insert the square cardboard sleeve into the flue to support the inner tube.

- 3.49 Cut through the flue and sleeve (see Diagram 11).

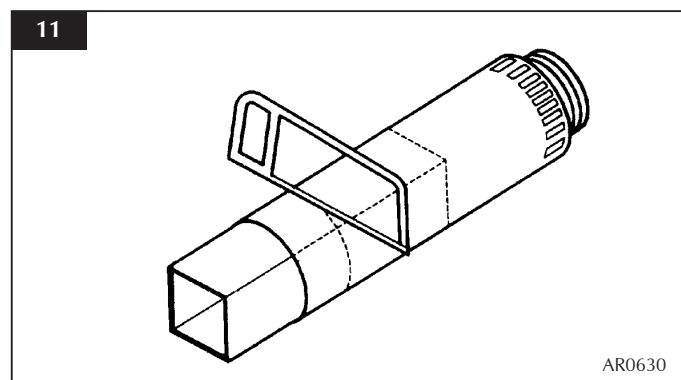

- 3.50 **REMOVE THE CARDBOARD REMNANTS FROM THE FLUE.**

- 3.51 File the cut edge smooth.

### Flue and Appliance Fixings

- 3.52 Pull appliance and flue assembly away from the hearth.

- 3.53 Drill four fixing holes for the wall plate and insert wall plugs supplied.

- 3.54 Put the horizontal flue onto the elbow and reposition the appliance.

- 3.55 Check the flue runs smoothly through the wall.

- 3.56 Fix the wall plate to the wall using the four black screws provided.

- 3.57 Drill through the fixing tab of the wall plate using a 3.5mm drill.

- 3.58 Secure with the screw provided.

- 3.59 Make good and weatherproof around the outside of the flue.

### TOP EXIT – VERTICAL FLUE

- 3.60 Where a vertical only flue system has been purchased, refer to *Installation & Instructions, Site Requirements, Section 6*.

- 3.61 Pay careful attention to the following:

- Terminal positions
- Flue supports
- Weatherproofing
- Fire precautions

# INSTALLATION INSTRUCTIONS

## INSTALLATION

3.62 Local and national codes of practice must be followed for all the above.

### TOP EXIT – VERTICAL ONLY, INCLUDING OFFSET

3.63 A restrictor must be fitted with vertical only flues. See chart below for restrictor sizes.

**PLEASE NOTE: When installing the appliance in conjunction with a vertical termination kit, there is a unique kit for use with this appliance (Gazco Part No. 999-539). This kit differs in that it has restrictors with sliding plates. Please ensure you have the correct kit before proceeding with the installation.**

Vertical Height from Floor	Restrictor Size
3000mm to 4990mm	52mm $\varnothing$
5000mm to 10000mm	47mm $\varnothing$

3.64 It is important that the sliding restrictor assembly is used. The restrictor assembly must be fitted with the slide collars uppermost and the top restrictor plate must be checked to ensure it moves freely before the flue is fitted.

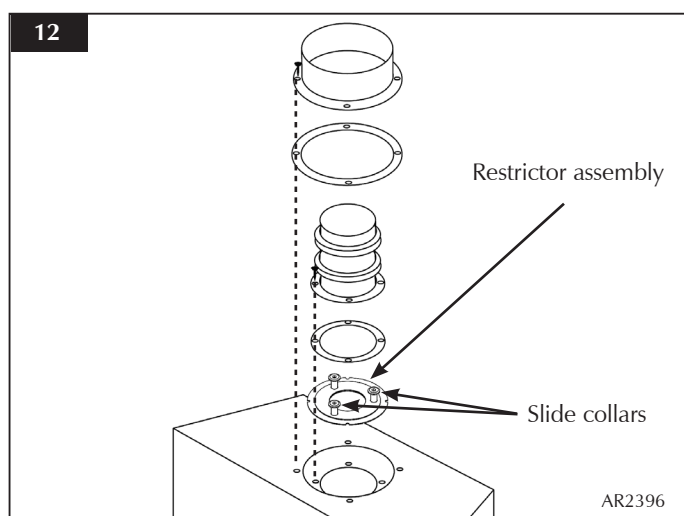

## 4. FUEL BED ARRANGEMENT

### ADVICE ON HANDLING AND DISPOSAL OF FIRE CERAMICS

4.1 The fuel effect logs and embers in this appliance are made from Refractory Ceramic Fibre (RCF). Protective clothing is not required when handling these articles, but we recommend you follow normal hygiene rules of not smoking, eating or drinking in the work area and always wash your hands before eating or drinking. Excessive exposure to these materials may cause temporary irritation to eyes, skin and respiratory tract; wash hands thoroughly after handling the material.

4.2 To ensure that the release of RCF fibres is kept to a minimum a HEPA filtered vacuum is recommended to remove any dust accumulated in and around the appliance.

4.3 When servicing the appliance it is recommended that the replaced items are not broken up, but are sealed into heavy duty polythene bags and labelled as RCF waste. RCF waste is classed as stable, non-reactive, hazardous waste and may be disposed of at a licensed landfill site.

4.4 After cleaning the appliance or replacing parts, carefully re-assemble the ceramic components.

### WHEN THE EMBERS ARE PLACED ON THE BURNER IT IS IMPORTANT THEY DO NOT COVER ANY PORTS!

The fuel bed is made up of embers and 6 logs, identifiable by molded letters:

4.5 Place Log A on the ledge at the rear of the appliance (see Diagram 13).

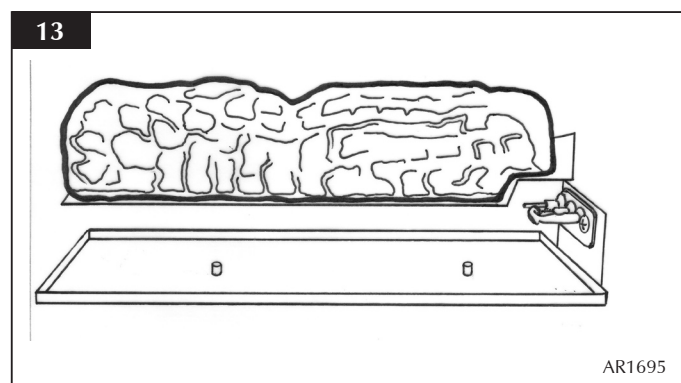

4.6 Place Log C onto the two studs on the burner skin (see Diagram 14A) with charred effect of the log facing forward (see Diagram 14B).

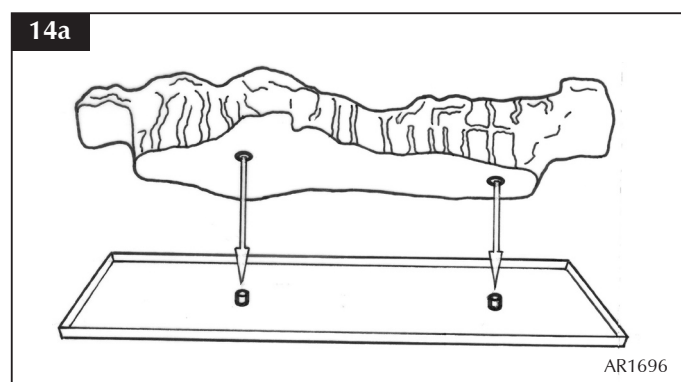

# INSTALLATION INSTRUCTIONS

## INSTALLATION

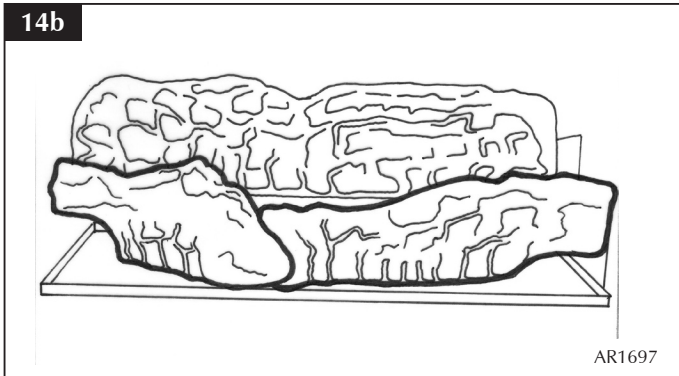

- 4.7 Put the embers on the burner around the positioned logs. **TAKE CARE NOT TO COVER ANY PORTS ON THE BURNER** as shown in Diagram 15.

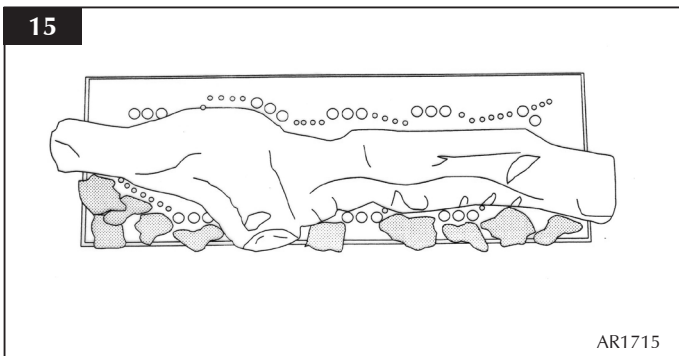

- 4.8 Place the log retainer in the two guides as shown in Diagram 16.

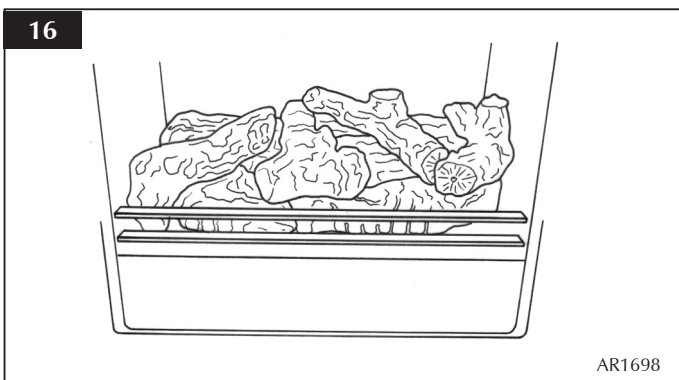

**FOR CLARITY, THE FOLLOWING LOG ARRANGEMENT DIAGRAMS DO NOT INCLUDE ILLUSTRATION OF THE RETAINER.**

- 4.9 Place Log D so that the back end sits in the groove in the rear of Log A (see Diagram 17A) and the front left rests in the groove in Log C (see Diagram 17B).

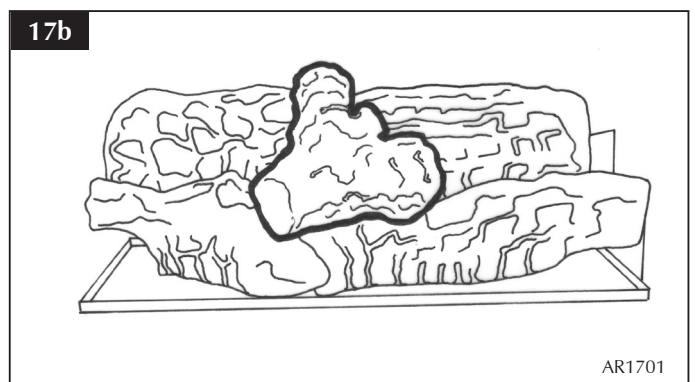
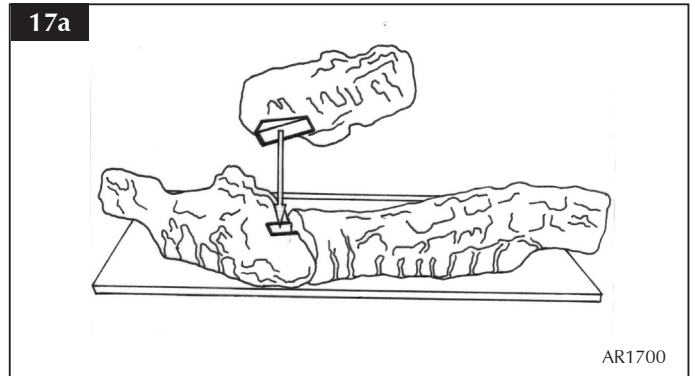

- 4.10 Position Log B so that the underneath rests in the groove of Log C (see Diagram 18A) and the end is in the corner of the burner (see Diagram 18B).

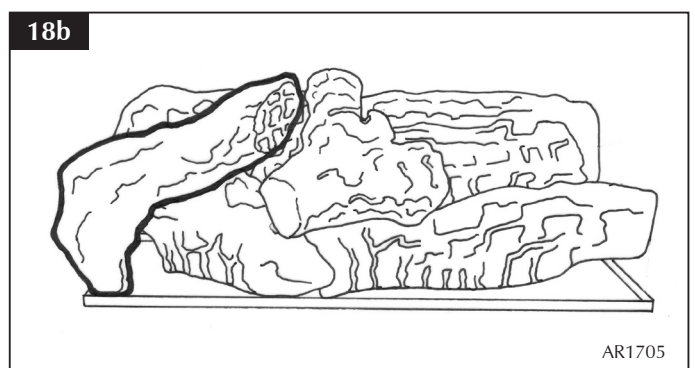
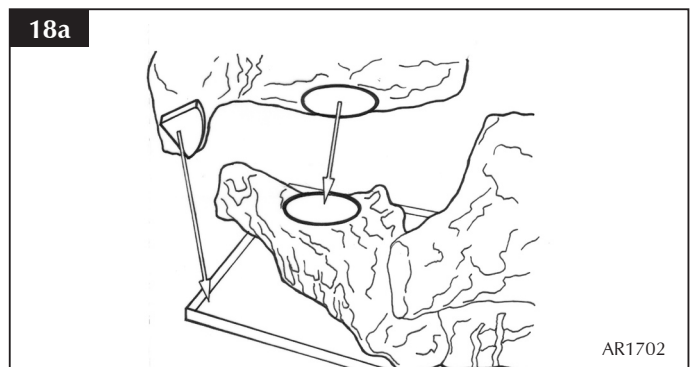

# INSTALLATION INSTRUCTIONS

## INSTALLATION

- 4.11 Put the groove underneath Log F onto Log C (see Diagram 19A) so that F is parallel to the side of the firebox (see Diagram 19B).

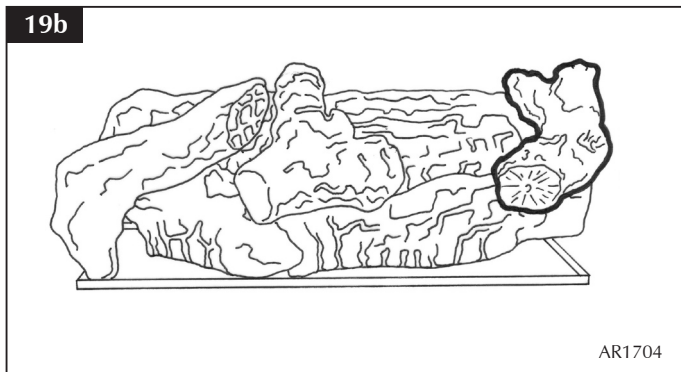
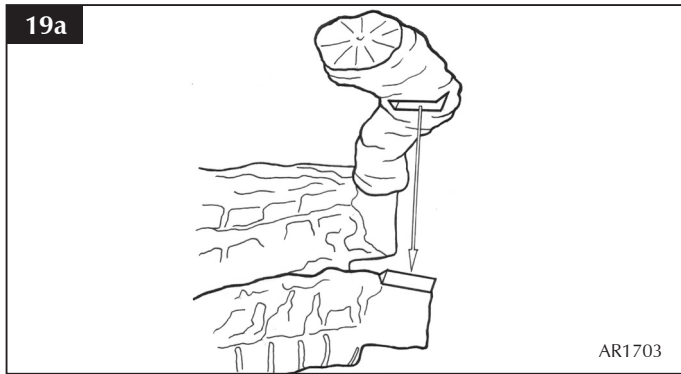

- 4.12 Place Log E into the groove between Log F and Log D (see Diagram 20A) so that it rests across logs A and D (see Diagram 20B).

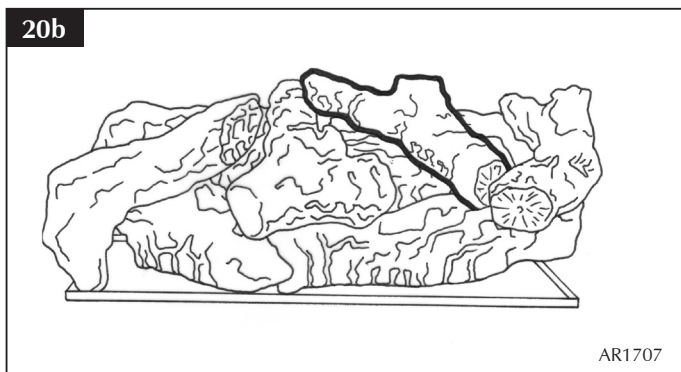
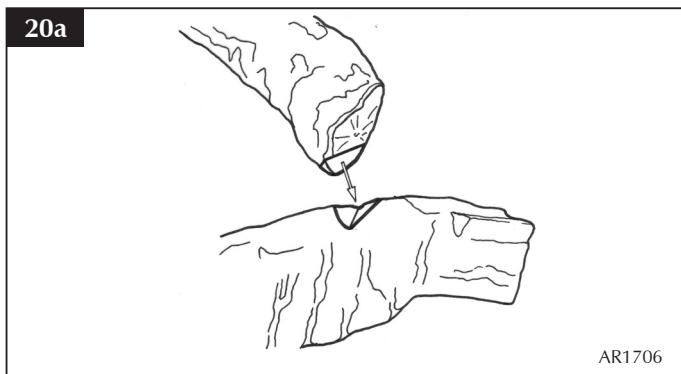

### REPLACING THE DOOR

- 4.13 Ensure the rope seal fitted to the rear of the glass frame is intact. Refit glass frame and tighten screws evenly

**NEVER OPERATE THE Appliance WHEN THE GLASS FRAME IS REMOVED, OR THE GLASS IS BROKEN.**

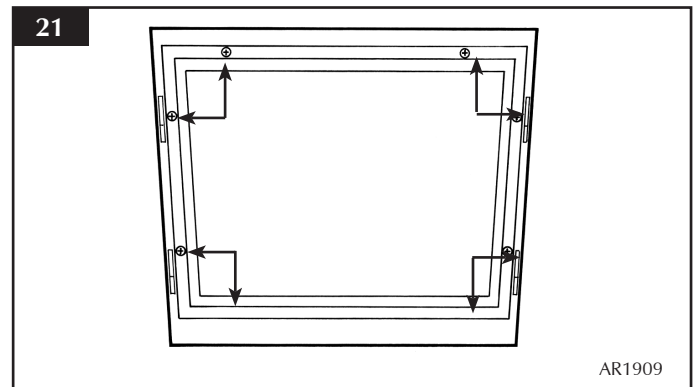

- 4.14 With the top still supported or removed refit front by locating in grooves and lowering into place (see Diagram 22).

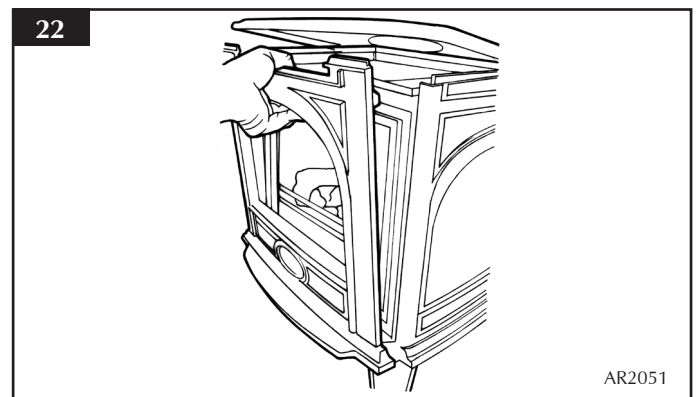

- 4.15 Replace top (see Diagram 23).

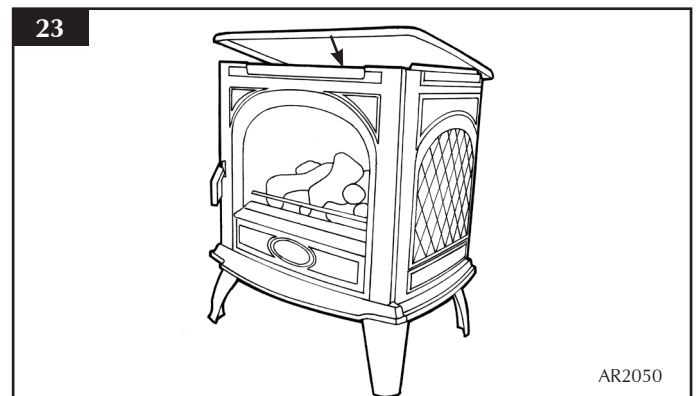

# COMMISSIONING

## 1. COMMISSIONING

**After connecting the gas pipe to the appliance:**

- 1.1 PURGE THE SUPPLY PIPE to dispel any debris that might block the controls.
- 1.2 Connect the gas supply to the 8mm compression elbow at the right-hand rear corner of the appliance (see Diagram 1).

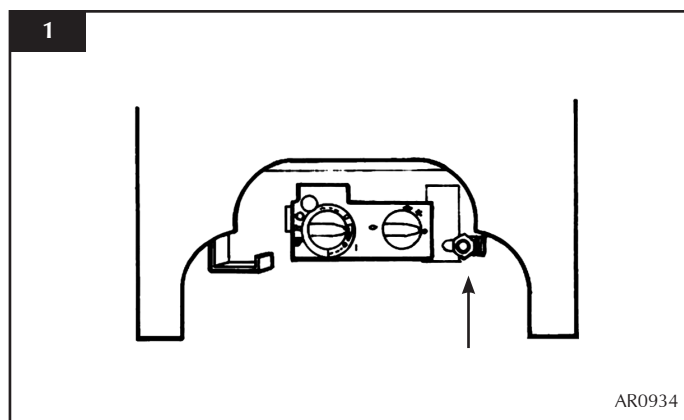

- 1.3 Connect a suitable pressure gauge to the test point on the inlet fitting.
- 1.4 Turn on the gas supply.
- 1.5 Light the appliance and check all gas joints for leaks.
- 1.6 Turn the appliance to maximum to check the supply pressure corresponds with the data badge information.
- 1.7 Turn the gas off.
- 1.8 Replace the test point screw.
- 1.9 Turn the gas on.
- 1.10 Check the test point for leaks.

**To finish commissioning:**

- 1.11 Check the appliance complies with all local regulations.
- 1.12 Check all seals are in good condition.
- 1.13 Complete the *Appliance Commissioning Checklist on page 3*.
- 1.14 Show the user how to operate the appliance.
- 1.15 Hand the completed instructions to the User for safe keeping. The information is required when making any guarantee claims.

# SERVICING INSTRUCTIONS

## SERVICING / FAULT FINDING CHARTS

### 1. SERVICING REQUIREMENTS

**IMPORTANT** – The glass panel on this appliance should be checked for any signs of damage on the front face of the glass panel (scratches, scores, cracks or other surface defects). If damage is observed, the glass panel must be replaced and the appliance must not be used under any circumstances until a replacement is installed. Please isolate the appliance until a replacement glass panel has been obtained and installed. Replacement glass panels can be purchased from Gazco via the retailer from which the appliance was purchased or any other Gazco distributor.

You must be competent to service this appliance.

You must follow the current Gas Safe Guidelines to achieve best practice results in all tests.

#### 1.1 Before Testing:

- Conduct a gas soundness test for the property ensuring there are no leaks before servicing.
- Check the operation of the appliance before testing.

#### 1.2 Special checks:

- Clean away lint or fluff from the pilot.

- Clean away lint or fluff from under the burner.
- Check the spark gap on the pilot is correct (see Diagram 1).
- Check all screws that secure the burner skin and tighten if they are loose.

1.3 Correct any faults found during the initial test.

1.4 Re-commission the appliance, conducting the usual safety checks.

1.5 Advise the customer of any remedial work undertaken.

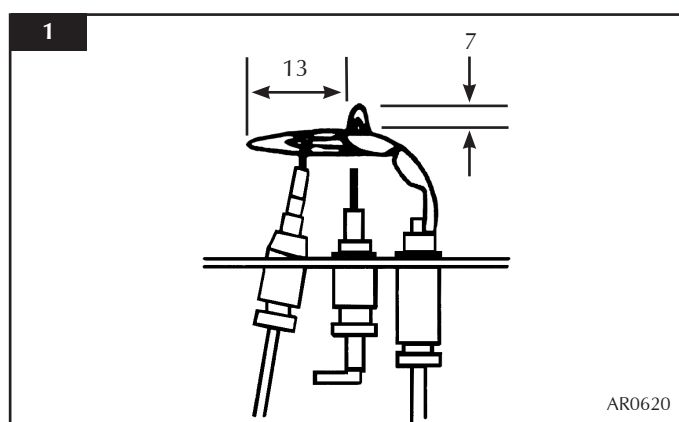

### IGNITION FUNCTIONAL CHECK 1

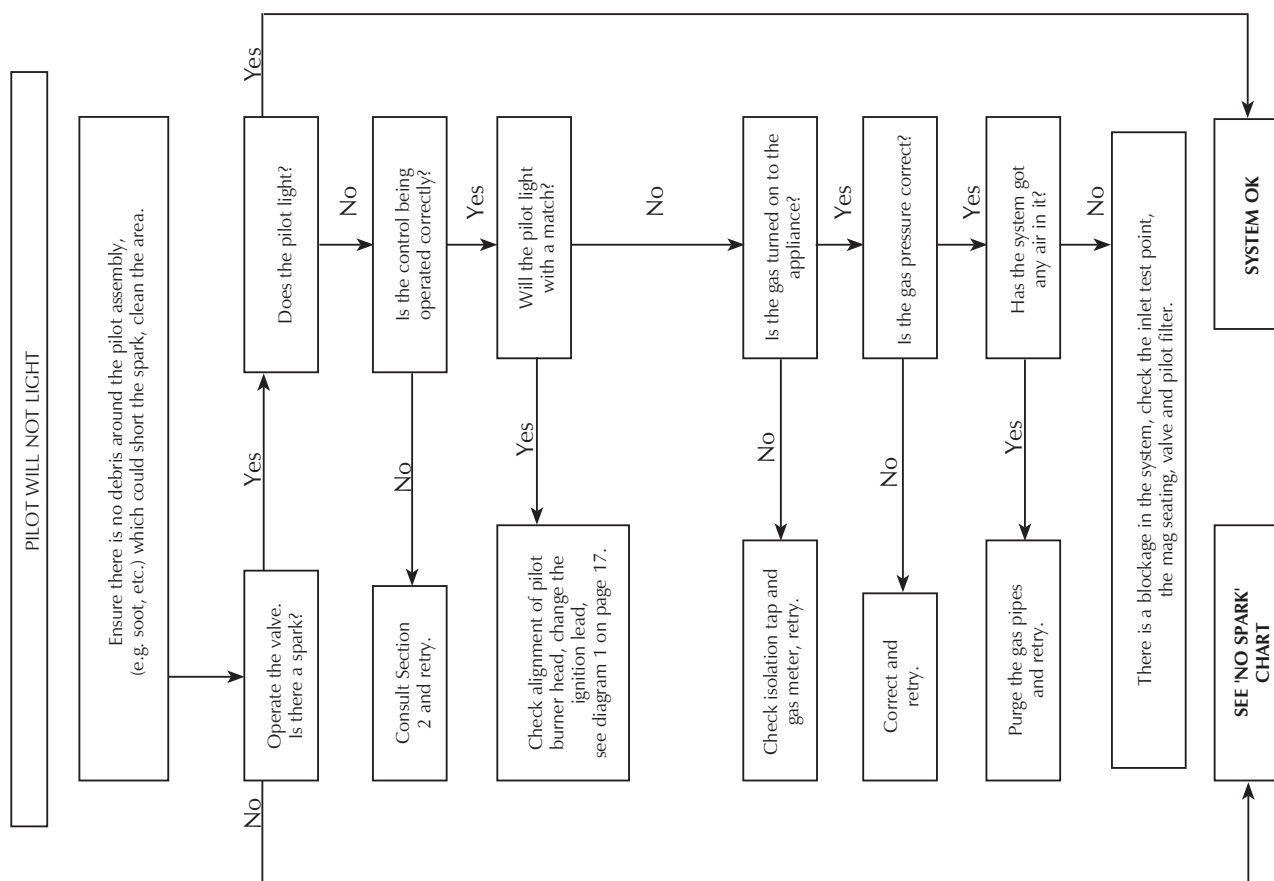

# SERVICING INSTRUCTIONS

## FAULT FINDING CHARTS

### FLAME FAILURE FUNCTIONAL CHECK

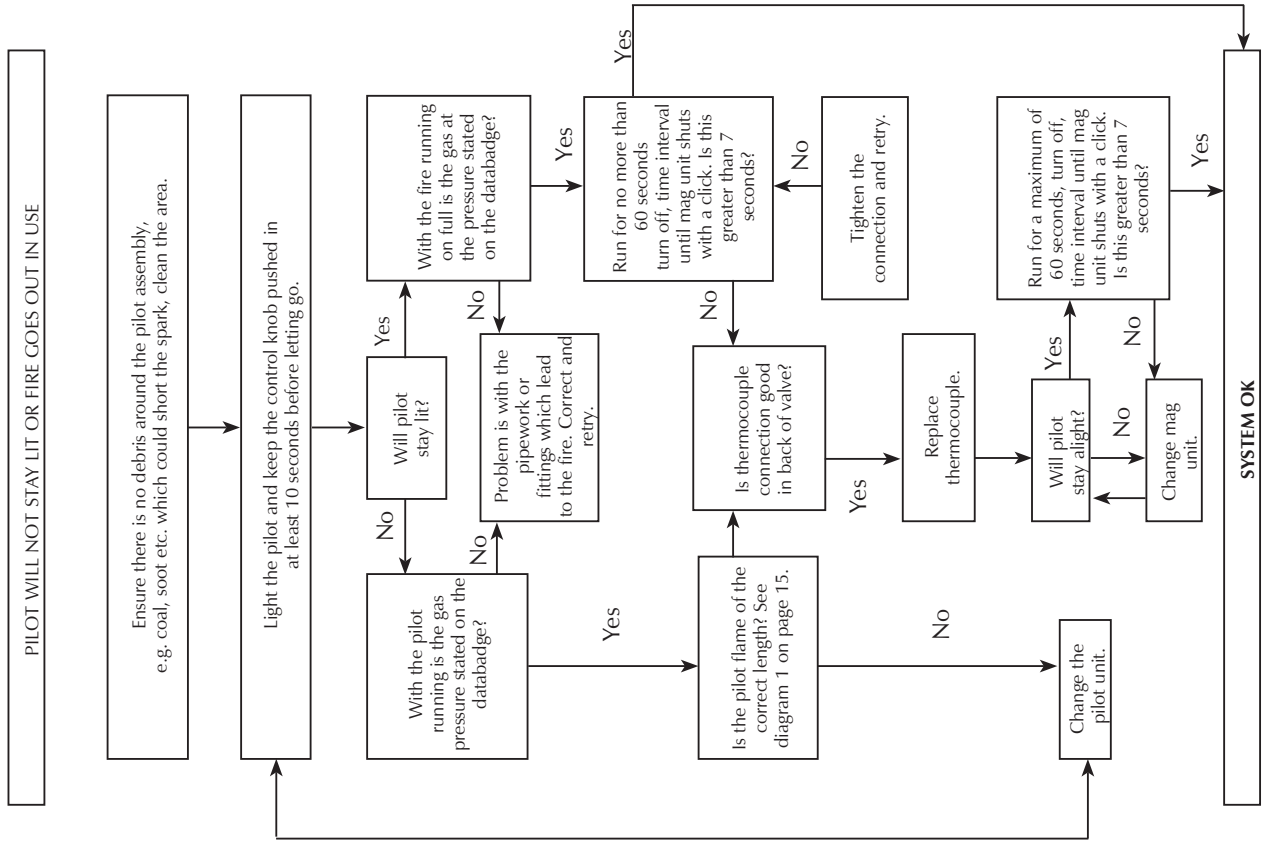

### IGNITION FUNCTIONAL CHECK 2

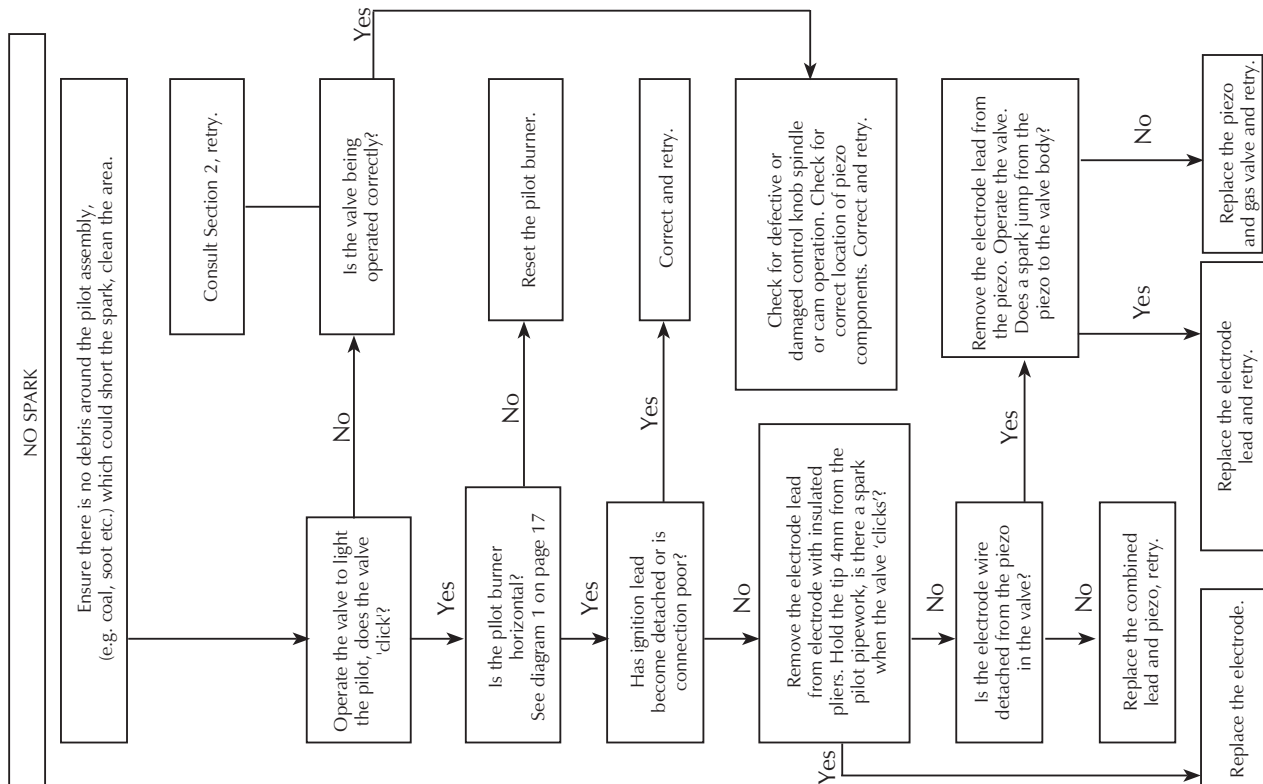

# SERVICING INSTRUCTIONS

## REPLACING PARTS

### 1. GENERAL

- 1.1 All main components can be replaced with the appliance in place but it is essential to turn off the gas supply at the isolation device before proceeding.  
For information on the handling and disposal of fire ceramics please refer to *User Instructions, Section 5, Cleaning the Appliance*.
- 1.2 Replace seals if the flue is to be removed.

### 2. MAIN BURNER

- 2.1 Turn off the gas supply at the isolation device and open the appliance door.
- 2.2 To remove the burner carefully remove the ceramic components and put to one side.
- 2.3 Remove the log retaining bar.
- 2.4 Take out the three screws holding the burner in place (see Diagram 1).
- 2.5 Raise the left side of the burner to clear the bracket.
- 2.6 Move the left-hand side of the burner forward.
- 2.7 The burner venturi is engaged over the injector, make sure you clear the injector when removing the burner.
- 2.8 **Do not damage the pilot burner** (see Diagram 2).

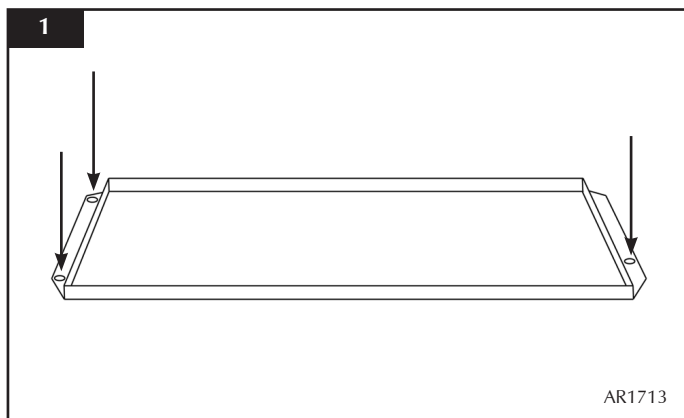

- 2.9 To replace the burner lower the right-hand side over the injector.
- 2.10 Lower the left side down.
- 2.11 Insert the three fixing screws and tighten.

**NOTE: Before replacing the burner, make sure the silicone seal around the injector is intact.**

### 3. PILOT UNIT

- 3.1 The pilot assembly has five components that can be replaced:
  - Pilot burner bracket
  - Pilot injector
  - Electrode
  - Thermocouple
  - Gasket
- 3.2 Turn off the gas supply at the isolation device.
- 3.3 Remove the burner following Section 2.
- 3.4 Remove the rear baffle.

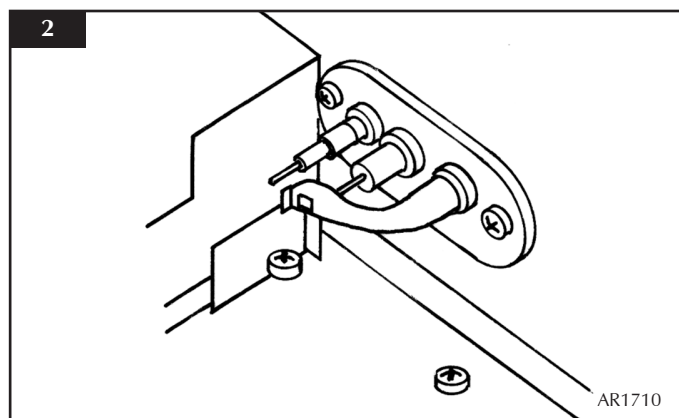

- 3.5 Remove the two fixing screws from the pilot burner bracket (see Diagram 3).

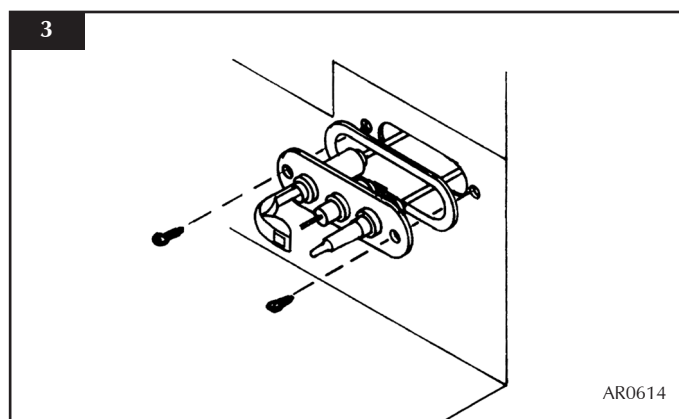

- 3.6 Carefully draw the pilot assembly away from the firebox. You now have access to the nuts and ignition lead.

# SERVICING INSTRUCTIONS

## REPLACING PARTS

**NOTE: Take care not to damage the gasket.**

### Pilot Injector

- 3.7 Undo the compression nut on the pilot feed pipe.
- 3.8 Extract the injector which is hooked onto the olive.
- 3.9 Make sure the new injector is hooked onto the olive before inserting into the pilot burner.

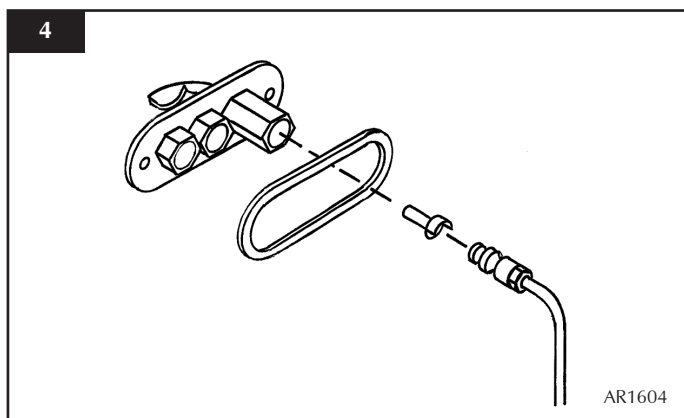

### Electrode

- 3.10 Disconnect the ignition lead.
- 3.11 Undo the retaining nut.
- 3.12 Remove the electrode, taking note of its orientation for re-assembly (see Diagram 5).

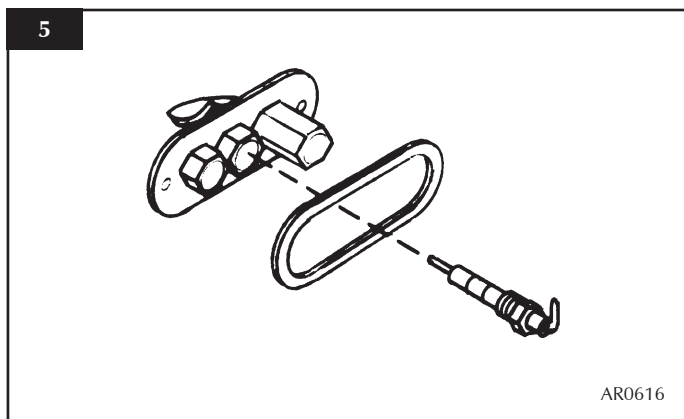

### Thermocouple

- 3.13 Undo the retaining nut.
- 3.14 Extract the thermocouple (see Diagram 6).

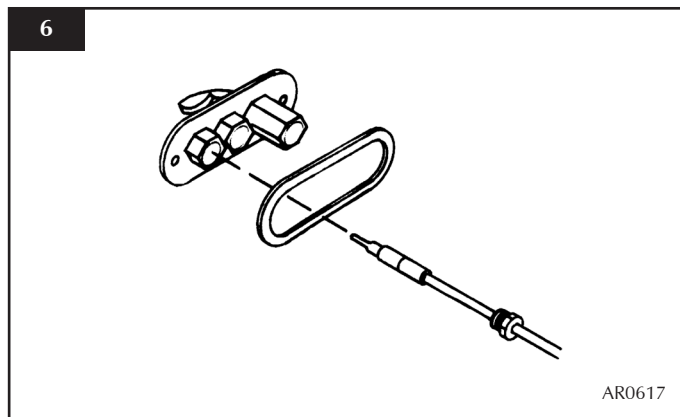

- 3.15 Undo the thermocouple at the gas valve end (see Diagram 7, A).

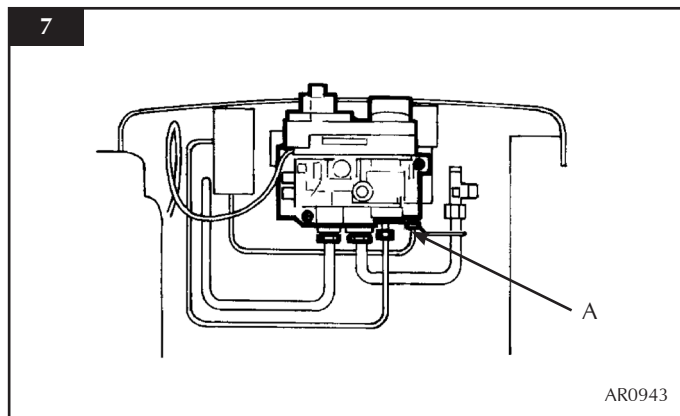

- 3.16 Re-assemble in reverse order.
- 3.17 Do not over-tighten.

### Gasket

- 3.18 Disconnect the four components outlined above.
- 3.19 Extract gasket.

**NOTE: Always replace the gasket first when re-assembling the pilot components.**

- 3.20 Check the pilot flame length.

## 4. IGNITION LEAD

- 4.1 To access the back of the pilot assembly, see Section 3 above.
- 4.2 Disconnect the ignition lead from the electrode.
- 4.3 Remove the front cover from the control valve (see Diagrams 8 and 9).

# SERVICING INSTRUCTIONS

## REPLACING PARTS

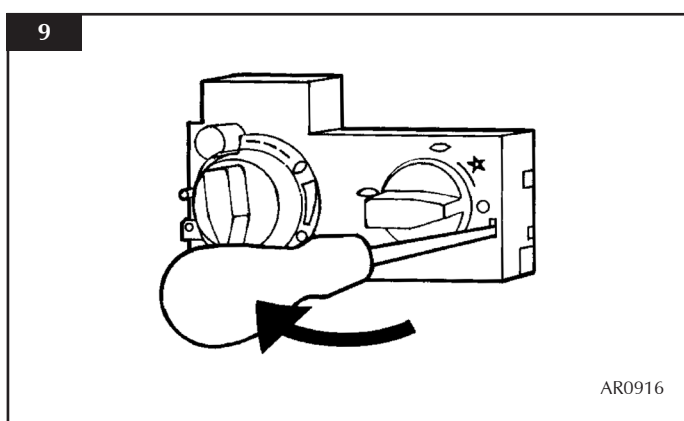
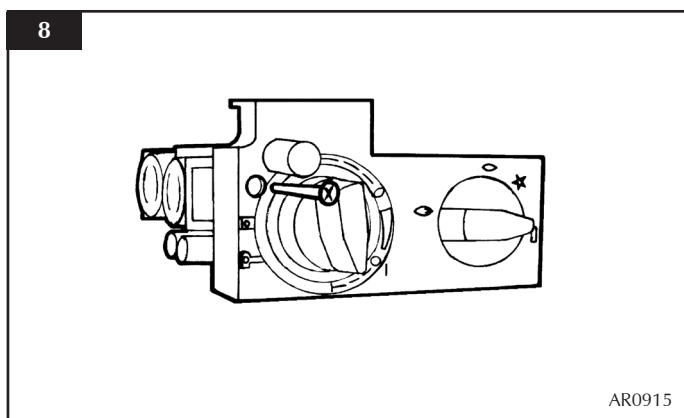

- 4.4 Disconnect the other end of the ignition lead from the gas valve, taking note of its orientation for re-assembly.
- 4.5 Replace with a new lead following the same route.
- 4.6 Check operation of new ignition lead.

### 5. PIEZO

- 5.1 The piezo assembly used on this appliance is not serviceable and is not likely to fail.

### 6. GAS VALVE

- 6.1 To remove the cover undo the single screw that secures the left side of the control cover (see Diagram 8).
- 6.2 Insert a narrow-blade screwdriver into the slot to release the right side of the cover (see Diagram 9).
- 6.3 When the cover is removed, there is a small cylindrical metal spacer to be kept and replaced on the fixing screw on re-assembly, unless the control has been upgraded to remote control.

- 6.4 To remove the valve turn off the gas supply at the isolation device.
- 6.5 Disconnect the 2 x 8mm and 1 x 4mm gas pipes at the back of the gas valve (see Diagram 10, A, also refer to Section 4).
- 6.6 Disconnect the ignition lead (see Diagram 10, B).
- 6.7 Undo the two bolts securing the gas valve to the appliance and remove the valve (see Diagram 10, C).
- 6.8 Replace in reverse order.
- 6.9 Check all joints for gas leaks.
- 6.10 Check operation of thermocouple and ignition lead.

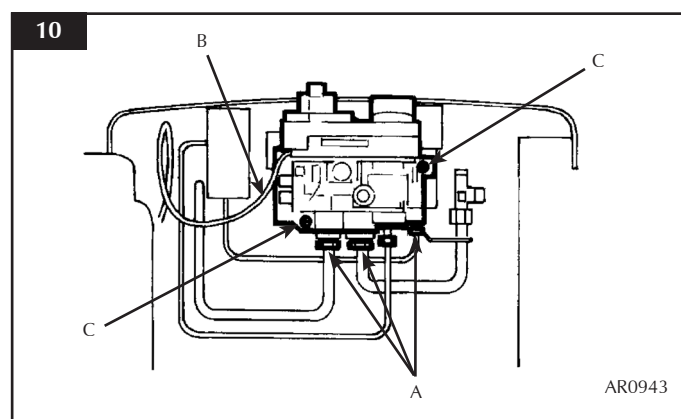

### 7. MAGNETIC SAFETY VALVE

- 7.1 To take out the magnetic safety valve remove the thermocouple lead from the valve.
- 7.2 Supporting the valve, unscrew the magnetic valve retaining nut and gently remove the safety valve.
- 7.3 Replace with a new unit.
- 7.4 Replace and tighten the retaining nut and thermocouple.
- 7.5 Carry out a leak test to ensure retaining nut is sealed.

### 8. MAIN INJECTOR

- 8.1 To remove the main injector turn off the gas supply at the isolation device.
- 8.2 Remove the main burner (refer to Section 3 above).
- 8.3 Undo the compression nut from the feed pipe at the gas control under the appliance.

# SERVICING INSTRUCTIONS

## REPLACING PARTS

- 8.4 Working from inside the firebox remove the lock nut from the injector (see Diagram 11).

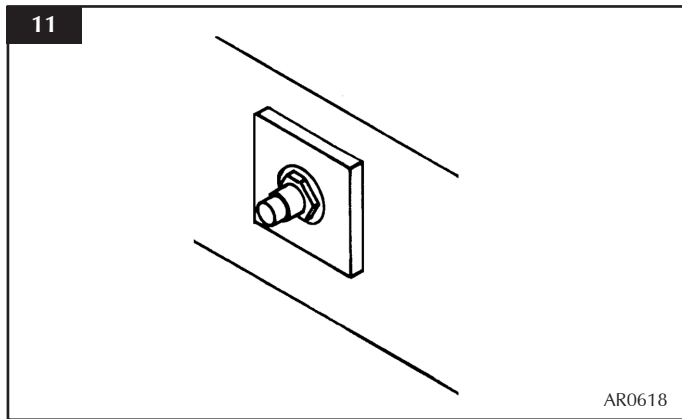

- 8.5 Extract the injector with the feed pipe from beneath the appliance.
- 8.6 Holding the injector with a spanner:
- 8.7 Undo the feed pipe. **Note the orientation of the Injector.**
- 8.8 Re-assemble in reverse order.
- 8.9 Turn on the gas supply and check for leaks.

### 9. PRIMARY AERATION PLATE

**NOTE: Not all models have aeration plates. Please refer to the *Technical Specification*.**

- 9.1 To replace the primary aeration plate turn off the gas supply at the isolation device.
- 9.2 Remove the burner, as described in *Installation Instructions, Replacing Parts, Section 2*.
- 9.3 Detach the aeration plate from the venturi (see Diagram 12).

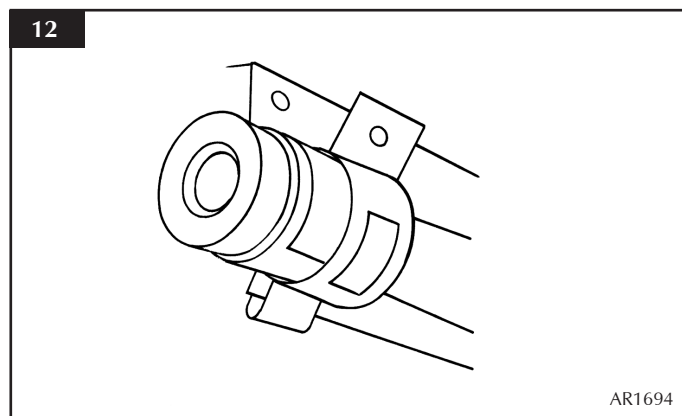

- 9.4 Reassemble in reverse order.

**NOTE: Even if no aeration plate is required, the small screw must be replaced.**

### 11. CHANGING BETWEEN GAS TYPES

In order to change between gas types you must change the following items:

- Pilot Injector
- Control Valve \*\*
- Main Injector
- Main Burner
- Aeration Plate
- Data Badge

**\*\*NOTE: THE CONTROL VALVE IS FACTORY-SET FOR THE CORRECT GAS TYPE AND MODEL. A NEW UNIT WILL NEED TO BE ORDERED WHEN CHANGING BETWEEN GAS TYPES.**

### 13. SHORT SPARES LIST

COMPONENT	NG		LPG	
	G20	G30	G31	
	20mbar	29mbar	37mbar	
BURNER UNIT	GZ5501	GZ5510		
AERATION PLATE	GZ3869	-	GZ3869	
MAIN INJECTOR	IN0060	IN0054		
PILOT INJECTOR	PI0026	P10015		
THERMOCOUPLE	PI0011			
MAGNETIC UNIT	GC0092			
ELECTRODE	PI0053			
PILOT GASKET	PI0052			
GAS VALVE	GC0088K **			
IGNITION LEAD	GC0090			
LOG SET	CE0565			
GLASS FRAME ASSEMBLY	GZ6025			

\*\*Note: The control valve is factory preset for correct gas type and model.

# SERVICE RECORDS

## 1ST SERVICE

Date of Service: .....  
Next Service due: .....  
Signed: .....  
Retailer's Stamp/Gas Safe Registration Number

## 2ND SERVICE

Date of Service: .....  
Next Service due: .....  
Signed: .....  
Retailer's Stamp/Gas Safe Registration Number

## 3RD SERVICE

Date of Service: .....  
Next Service due: .....  
Signed: .....  
Retailer's Stamp/Gas Safe Registration Number

## 4THE SERVICE

Date of Service: .....  
Next Service due: .....  
Signed: .....  
Retailer's Stamp/Gas Safe Registration Number

## 5THE SERVICE

Date of Service: .....  
Next Service due: .....  
Signed: .....  
Retailer's Stamp/Gas Safe Registration Number

## 6THE SERVICE

Date of Service: .....  
Next Service due: .....  
Signed: .....  
Retailer's Stamp/Gas Safe Registration Number

## 7THE SERVICE

Date of Service: .....  
Next Service due: .....  
Signed: .....  
Retailer's Stamp/Gas Safe Registration Number

## 8THE SERVICE

Date of Service: .....  
Next Service due: .....  
Signed: .....  
Retailer's Stamp/Gas Safe Registration Number

## 9THE SERVICE

Date of Service: .....  
Next Service due: .....  
Signed: .....  
Retailer's Stamp/Gas Safe Registration Number

## 10THE SERVICE

Date of Service: .....  
Next Service due: .....  
Signed: .....  
Retailer's Stamp/Gas Safe Registration Number



United Kingdom and Eire distributors for Dovre:

**STOVAX**

**Stovax Limited**, Falcon Road, Sowton Industrial Estate, Exeter, Devon, England, EX2 7LF.

Telephone: (01392) 474011 Fax: (01392) 219932

E-mail: [dovre@stovax.com](mailto:dovre@stovax.com) Internet: [www.dovre.co.uk](http://www.dovre.co.uk)